

INTENSIONALLY LEFT BLANK

Table of Contents

Introduction

Section 1 - Introduction to Masonry Strengthening and Reinforcement

Section 2 - General Approach and Design Philosophy for Cintec Systems

Materials, Substrate, Forces, Applications

Section 3 – Useful Information

Section Properties for Round and Square Steel Sections

Area per anchor – Domino 5 Stitching Pattern

Section 4 - Design Data

Bond pull out area

Bearing area

Pull out capacity

Typical substrate strengths

Presstec grout strengths

Section 5 – Design Tools

Section capacity equivalents- tensile and bending

Section 6 - Sample Specifications and Details

Named Spec

Generic Spec

Typical Project Definitions

Typical Details

Anchor Design and Selection Matrix

Section 7 - Installation, Drilling & Quality Assurance.

Section 8 - Sustainable Design

Section 9 - Special Applications

Seismic

Blast Protection

Progressive Collapse

Civil Engineering

Section 10 – Test Data, Technical References, Standards

Cintec Web Site

Cintec Test Data

ICCS

Section 11 – Graphics

Standard Details

APPENDIX A Technical Drawings For Engineers & Architects information.

APPENDIX B Salient points for use of Cintec Reinforcement Systems

APPENDIX C Training Course FOR INSTALLERS USING THE CINTEC REINFORCEMENT & ANCHORING SYSTEM



Introduction.

This manual has been produced for Engineers and Architects in North America in order to have a better understanding of the Cintec Anchoring System.

It would be very much appreciated if you could send any comments and suggestions to engineering@cintec.com so that we can incorporate them in the next revision.

Robert Lloyd-Rees, FFB
Chief Operating Officer
Cintec Reinforcement Systems

JUNE 2020

Section 1 - Introduction to Masonry Strengthening and Reinforcement

Preamble

When we speak of strengthening there is an assumption that the masonry is existing and that it is deficient in some way.

This deficiency can take two forms. In the first case, the masonry may have deteriorated to the point where it can no longer perform the functions for which it was intended or safety is compromised. In the second case, it may need to be reinforced to take new loads.

Prior to the recent development of the strengthening method, standard practice was to dismantle and rebuild deficient masonry. This is a very disruptive and costly process, hence the impetus to find alternative methods.

Masonry comes in a number of configurations, including:

- Solid (single wythe)
- Composite (multiple wythes bonded together structurally)
- Cavity (multi wythe tied together)
- Rubble (two wythes with rubble fill)

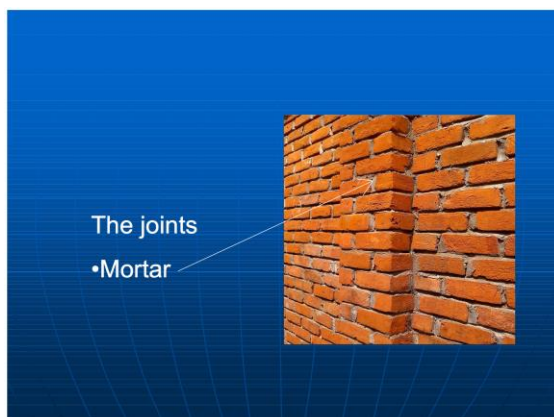

The main components of masonry are masonry units, mortar and reinforcement.

Masonry units can be brick, terra cotta, CMU, adobe, stone, or precast concrete.

These units are usually bedded in and separated from each other by a bed of mortar. In some cases the masonry is laid up without mortar, such as dry stone walls.

Reinforcement can take the form of reinforced concrete elements built into the wall, embedded metal members, external reinforcement applied to the face of the wall, or external structural elements.

Engineering Considerations

General

The structural strengthening methods covered in the other chapters of this document can generally be applied to masonry.

These include section enlargement, externally bonded systems, post-tensioning, and virtual strengthening.

Masonry is not strong in tension, shear and bending. Its main value as a structural material is in compression. However, all these characteristics can be improved through strengthening.

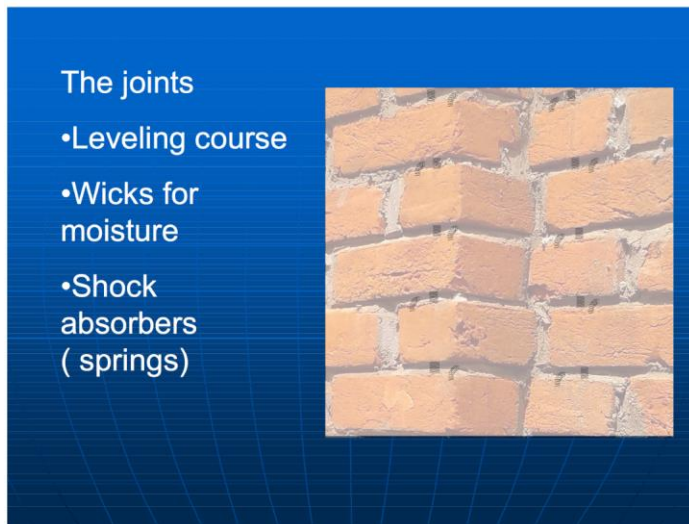

The weakest element of a masonry system is typically the mortar. This is intentional.

Mortar is intended to be the component that “wears out”. The mortar should act as a wick to allow moisture to exit the wall through evaporation. In so doing, the mortar (in northern climates) is exposed to many more cycles of freeze-thaw than are the masonry units.

If the mortar is ineffective as a wick for the moisture that may enter the wall, then the moisture is forced out

through the masonry units, leading to freeze-thaw damage at both the interior (cavity) face and the exterior face. This leads to lose of the face of the unit. This type of damage can only be effectively remedied by complete replacement of the unit.

It is much easier to repair the deteriorated mortar on a regular basis than it is to replace the actual masonry units.

The mortar, when well designed, should act as a spring in the masonry system. Mortar that is more ductile and weaker than the main units will absorb uneven stress distributions. These stress concentrations may be due to impact, settlement, thermal and overload.

The most common cause of masonry failure is the replacement of weak mortar with a much stronger mortar in a well-intentioned but misguided attempt to “strengthen” the masonry elements.

This is common where soft, permeable lime-based heritage mortar is repointed with a very strong and dense Portland cement mortar.

The new, impermeable mortar dams up the moisture in the wall, causing it to exit through the masonry units. The salts found in Portland cement are deposited on the face of the units through evaporation.

This is the unsightly efflorescence we see on the face of the units, leading to added costs for surface cleaning.

This accumulation of salts clogs the pore structure of the masonry units and accelerates the deterioration of the units when exposed to freeze-thaw conditions.

The insertion of a very hard, inflexible element at the front edge of the masonry units causes the face of the masonry units to be subjected to a very high compressive and shearing stress.



Failure due to hard mortar repointing

This combination of freeze- thaw damage and knife edge stress loading can cause very rapid failure of the face of the masonry units.

If the evaporation face is at the inner face of the exterior masonry units, facing a cavity, then the debris falling from the units accumulates in the cavity, leading eventually to a wedging action of the debris. This is the most common cause of bulging at lines of horizontal support.

The next most common cause of masonry failure is corrosion of ferrous metals.

Steel and iron elements are embedded in masonry for various reasons. Steel frames are embedded in masonry for fireproofing and aesthetic reasons. This was particularly prevalent in structures from the 1920's and 1930's.

Unprotected steel angles are also used as shelf angles at regular interval in structures to support masonry veneers.

We also see corrosion of galvanized material used in anchoring or another application within the masonry.

Water enters the masonry as the masonry deteriorates. This moisture promotes corrosion of the steel leading to oxide jacking. The products of corrosion can be 3 to 4 times the volume of the parent material, creating very high lateral forces. These lateral forces open up cracks and joints in the masonry, leading to more water ingress and a vicious cycle of ever accelerating deterioration.

Seismic Reinforcement

Seismic upgrading is a growing use for masonry strengthening. External and internal system can be used.

In addition to increasing the shear, axial and bending strengths of the masonry, reinforcement also increases the ductility of the masonry. This is a very important performance improvement for seismic retrofit.

Historic Masonry

Appearance and compatibility are important considerations in selecting masonry strengthening methods for historic structures.

External systems tend to disrupt the appearance of the structure. Internal systems are concealed.

As much as possible preservationists prefer using materials that are compatible with the original materials, and systems that are reversible.

Polymers are a modern material and are deemed to be incompatible. Cement based products are historically compatible.

Cintec works to the guidelines of the principles of the Venice Charter of 1964 and the Burra Charter of 1979. In the United States Cintec works to the guidelines of the Secretary of the Interior's Standards for historic rehabilitations.

Blast Protection.

Many of the proposed strengthening methods contribute to the resistance of the structure to blast loads, intentional or accidental.



Blast loads have a similar effect on masonry structures to seismic loads and damage levels can be comparable.

Internal reinforcement probably offers the best protection, and has the added benefit of providing post-blast intrusion protection, however it is costly.

External reinforcement has the advantage of containing shrapnel but is limited where appearance is a consideration.

Systems, Methods and Materials

Traditional Methods.

Traditional methods of strengthening masonry include:

- Replacement of mortar (repointing)
- Replacement or repair of individual units
- Rebuilding of sections of a wall

These methods may appear to be repair methods rather than strengthening methods. However, when any of these methods are required, it means the structure is deficient and these methods will increase the overall strength of the structure.

Individual Unit Strengthening

Masonry by definition is made up of prefabricated units that can normally be manhandled. They are most commonly made from naturally occurring mineral material. These prefabricated units themselves may deteriorate for various reasons, including freeze-thaw, defective fabrication and inappropriate chemical treatment or cleaning.

Strengthening of individual units can be done but this has limited application.

Mortar joints are intended to be the component that “wears out”. The practice of joint repointing was developed as the main strategy for repair and strengthening. Replacement of mortar with a higher strength material is strongly discouraged.

Joints in ashlar type construction (rectangular units, straight joints) may be strengthened to increase load-bearing capacity by introducing a thin steel wire reinforcement in a slot cut in the mortar. This method is only used where there is a very specific need as the cost is high. This is used to increase the resistance of the system to out of plane loads such as seismic and wind.

Repair of masonry units usually involves replacement if the units are small.

In the case of large units, a repair using internal reinforcing anchors or applied patches of compatible material.

Hollow masonry units such as CMU and terra-cotta may be strengthened by injection (grouting) of a compatible material. Grouting systems normally require a method to contain the grout to prevent intrusion into areas where grout is not required or is undesirable.

Internal reinforcement in the form of an anchor may be in part due to the injected material. Fire resistance and freeze thaw resistance are criteria properties to be considered in the selecting this type of reinforcement.

Externally Bonded Reinforcement

External reinforcement is normally used where appearance is not a concern. Many masonry structures utilize the exterior and/or interior surfaces of the masonry as the architectural finish, thus limiting the use of external reinforcement.

Many masonry systems have rough or decorative faces, thus also limiting the use of external reinforcement.

Typical installations involve application of metal or composite reinforcing members on the face of the masonry. Attachment is by mechanical fasteners and/or chemical adhesives.

External reinforcement may be post-tensioned. Fireproofing of external reinforcement can be a major cost and aesthetic concern.

Section Enlargement

While section enlargement is completely feasible, it does not find widespread use.

Masonry structures are usually quite bulky by their nature and the addition of extra volume can create appearance, space and clearance problems.

Shotcrete is one of the methods of section enlargement that is available for existing masonry structures.

Internal Strengthening

Internal strengthening can be perpendicular to the face of the masonry system or in the plane of the system.

Perpendicular strengthening involves tying together the deteriorated masonry or tying the wythes of composite or cavity systems.

This type of reinforcement can be mechanical, adhesive or both in the case of grouted anchors installed in holes drilled perpendicular to the wall face.

In-plane internal reinforcement can be in any direction in the plane of the wall. Most applications involve drilling of long holes and insertion of a metal anchor body, which is then grouted.

In some cases the existing void or core built into the units, such as occurs in CMU and terra cotta, can be used to accept the reinforcement.

The air space in a cavity system may also be used to accommodate in-plane reinforcement. This is not usually an accepted practice as the introduction of reinforcement in the cavity may defeat the original design requirement for the cavity as a integral part of the building envelope. The reinforcing element is bonded and encased in an injected material, either a polymer or a cement-based grout.

Care must be taken in this type of application, particularly in seismic zones, that the mass is not increased and the load paths are not changed.

In-plane reinforcement can increase in-plane compressive, shear and tensile strength and out-of-plane shear and bending strength.

Internal reinforcement can be post tensioned. Post tensioning is advantageous as a strengthening method as it induces compressive stresses in the masonry. This reduces the occurrence of tensile cracks in the system.

As with other systems, fire resistance and resistance to freeze-thaw damage should be considered in selecting an internal reinforcement system.



Dust – free Directional Drilling

Internal Reinforcement and Lateral Tying

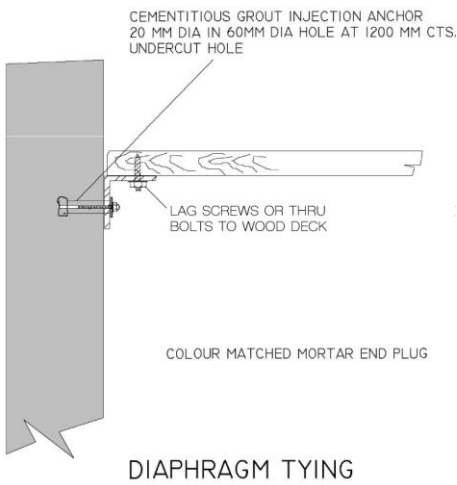
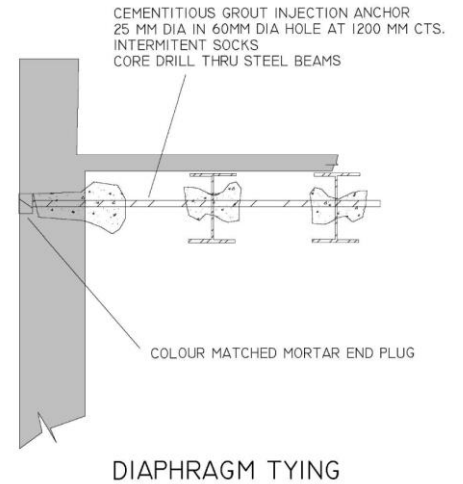
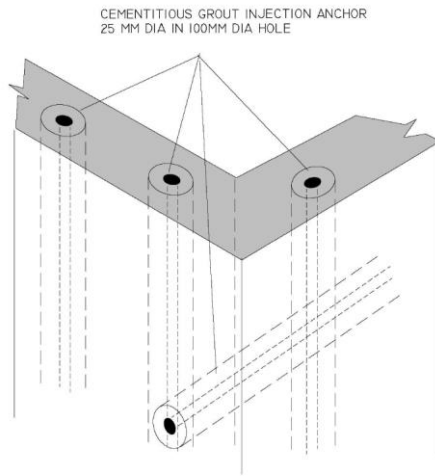
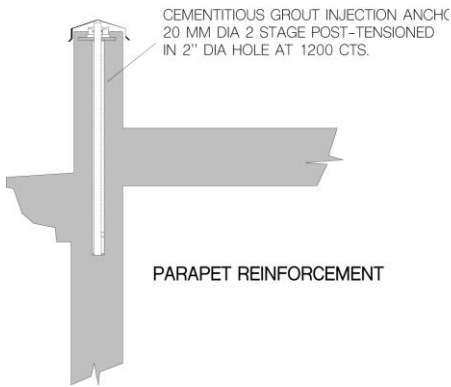

Internal Reinforcement

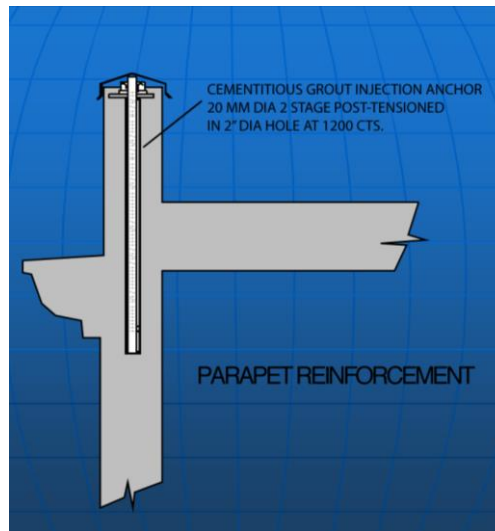

Parapet post tensioning

Modern Developments

Recent advances in directional drilling have led to new applications in internal reinforcement.

Advances in material sciences related to CFR, polymer adhesives and micro-fine grouts have led to new ways of applying strengthening methods.

Recent advances in cathodic protection provide a means to stop corrosion of embedded metals.

Virtual Strengthening

Many masonry structures were designed under empirical design rules, or even by traditional rules of thumb.

There is much scope for the use of virtual strengthening in assessing such structures.

Recent developments in codes for existing structures are now allowing greater latitude in allowable stresses for structures that have stood the test of time.

Most masonry structures also benefit from a tell-tale element built right in – the mortar.

As the weakest and most easily repairable element in the masonry system, the mortar and its condition are good indicators of the structural integrity of the entire system.

Advanced non-destructive testing (NDT) methods such as flat jacks and shove tests are a great help in assessing this. Details and discussions on these tests and many others can be found in reference websites and texts on non-destructive testing (NDT).

Full scale load testing can also be used to confirm the actual capacity of masonry systems.

Durability

Some elements of the masonry system are intended to be maintainable – they “wear out”. (e.g. mortar). These elements are expected to be an on-going preventative maintenance task.

Ferrous metals must be protected from corrosion. Synthetics must be protected from ultraviolet rays.

The durability of any repair or strengthening will be very dependent on the successful elimination of the root cause of the deterioration or deficiency. We must treat the cause not the symptom.

A good case in point is oxide jacking of encased steel members. Elimination of water ingress through effective repairs to joints and waterproofing helps this situation.

However, there is still potential for the corrosion to continue, causing reoccurrence of the problem. Developments in cathodic protection provide a means to mitigate this problem.

Fire Considerations

Internal reinforcement systems are normally provided with fire resistance by the original masonry system.

In the case of exposed steel, composites and adhesives, this is accomplished by encapsulation with a fireproof material. Cement based grouting systems are inherently fire resistant.

Field Applications

The masonry strengthening methods discussed here have been used for some time in North America.

The more innovative and cost-effective strengthening methods are gradually replacing the traditional “demolish and replace” approach to masonry repair and strengthening.

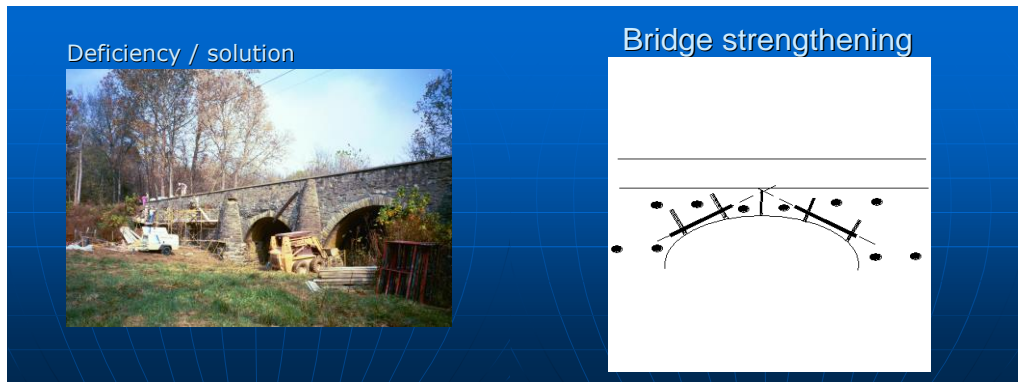

Case Study 1 Bridge strengthening

Deficiency / solution

- Pin the arches
- Install internal tie rods
- Stitch bulging area
- Grout interior voids
- Joints?



Benefits and Limitations

Benefits

The main benefits of strengthening versus the traditional demolish and replace approach are:

- Time saving
- Cost effectiveness
- Reduction in disruption to the facility

Case Study 2 – Historic Blast furnace strengthening

Limitations

The cost of masonry repairs and strengthening often approaches the current Asset Replacement Value (ARV).

The biggest cost element in strengthening is usually the access (scaffold) regardless of the method of strengthening selected.

Suitable methods to strengthen masonry are limited in many cases because the surfaces are decorative, it is rough cut stone or it is protected by heritage designation.

These limitations usually preclude external reinforcement or section enlargement.

Section 2 - General Approach and Design Philosophy

Cintec Design Parameters

For stone, brick and terra cotta masonry

1. For many applications and designers, the use of Allowable Stress Design (ASD), is appropriate, and thus the focus of this manual is on that method. It is also known as Working Stress Design (WSD) in parts of North America. The same procedures can be adapted to the Limit State Design (LSD) method or Load Factored Resistance Method (LFRD) where design consistency is required with other parts of the project.
2. Bond pull out strength is typically 65PSI (working stress) on the circumference of the drilled hole. This is based on 4x safety factor based on actual full-scale load tests. This may be reduced in very dense, smooth substrates like granite to as low as 30 PSI
3. Steel is typically AISI Type 304 stainless with a yield of 30,000 PSI. We use 0.6 as the strength reduction factor for WSD in bending, 0.66 in tension and 0.4 for shear.
4. Safe bearing strength for shear loads and/or bending stresses from eccentric loads on sound brick masonry is 300 PSI. Bearing area is calculated on one- half the circumference of the hole, not the projection of the hole diameter.
5. The sum of the interaction formula for combined stresses shall not exceed 1.0
6. Pull out and bearing strength of the substrate is based on the ACI standard procedure using an appropriate diagonal tensile stress. Pull out strength in terra cotta units is based on a very conservative value and load tests have always proven that the failure load is much higher than we calculate.
7. The anchors system tends to fail in the substrate. The steel anchor body typically does not fail, and the grout element does not fail in crushing or pull -out if the grout installation has been performed in accordance with Cintec requirements. Therefore, design should focus primarily on determining the properties of the substrate.
8. Test anchors must be designed to ensure the design parameters sought are the end result. Cintec should be consulted on the overall test design.

Design Methods for Cintec Grout Anchors

The standard design checks that are performed on any design are:

Cone Pull Out Resistance: To ensure that the parent material around the anchor does not fail in tension.

Tensile strength of the steel anchor body: To ensure that tensile failure does not occur in the anchor body.

Shear strength of the steel anchor body: To ensure that shear failure does not occur in the steel anchor body

Bond Pull-out Resistance: To ensure that the bond between the Cintec grout and the substrate does not fail in pull out. In the case of hollow units (CMIU or terracotta) the shear on the enlarged grout bulb and the shear failure load of the thin wall of the hollow units must be checked.

Mortar Joint Check: To ensure that the mortar has sufficient strength to transmit the loads from individual anchors into the global masonry substrate.

Bearing Resistance of the Substrate: To ensure that the parent material does not fail in crushing in the vicinity of the anchor.

Shear Resistance Toward the Free Edge of the Parent Material: To ensure that the parent material does not fail in shear due to anchor loads perpendicular to a free edge.

Engineering Principles.

Design procedures contained in the publications of the American Concrete Institute (ACI), the Prestressed Concrete Institute (PCI), the Portland Cement Association (PCA), masonry industry sources and the model building codes are used for calculating the loads and resistances.

A critical step in the process is the assessment of the strength of the parent material (substrate). As this can often only be undertaken by visual inspection of the materials, an educated estimate of the strengths of the material in-situ must be made by designer.

Sources for data can be derived from historic engineering and builders' textbooks and suppliers' catalogues.

Section 3 – Useful Information

Properties of Steel Sections

Anchor Body Designations

HSS= Hollow Square Section, not threaded

CHS= Circular Hollow Section - normally not threaded, therefore no section reduction

SRT= Solid Round Threaded - section reduction for threads full length

SRD= Solid Round Dywidag Threadbar - no section reduction at coupler

SRR= Solid Round Rebar- section reduction for coupler threads at ends

SRS= Solid Round Smooth - section reduction for coupler threads at ends

CRR= Carpenter Solid Round Rebar - section reduction for coupler threads at ends

Cintec uses Imperial dimensioned steel and components in its manufacturing for North America. When a specification is written in Metric format the nearest Imperial dimensioned product will be used. As examples, 10mm = 3/8 inch, 20mm = ¾ inch

IMPERIAL
Area(s) shown as square inches

Imperial Section Properties

Type	Size	Nominal Area sq. In.	Gross Area sq. In.	Shear Area sq. In.	M.Inertia I (in.) ⁴	Section Modulus (in.) ³
HSS	1 x 1 x 1/8	0.403	0.376	0.151	0.047	0.093
HSS	1 1/4 x 1 1/4 x 1/8	0.528	0.492	0.210	0.102	0.162
HSS	1 1/2 x 1 1/2 x 1/8	0.590	0.551	0.268	0.160	0.214
HSS	2 x 2 x 1/8	0.903	0.841	0.384	0.487	0.487
HSS	2 x 2 x 3/16	1.281	1.195	0.515	0.641	0.641
HSS	2 1/2 x 2 1/2 x 1/4	2.111	1.970	0.838	1.624	1.299
CHS	3/8 diameter x .04	0.042	0.039	0.020	0.005	0.029
CHS	1/2 diameter x .11	0.135	0.128	0.064	0.026	0.103
SRT	3/8 diameter	0.110	0.078	0.078	0.000	0.003
SRT	½ diameter	0.196	0.142	0.142	0.002	0.008
SRT	5/8 diameter	0.307	0.226	0.226	0.004	0.015
SRT	3/4 diameter	0.442	0.334	0.334	0.009	0.027
SRT	7/8 diameter	0.601	0.459	0.459	0.017	0.044
SRT	1 diameter	0.785	0.606	0.606	0.029	0.067
SRT	1 1/4 diameter	1.227	0.969	0.969	0.075	0.135
SRT	1 3/8 diameter	1.485	1.155	1.155	0.106	0.175
SRT	1 ½ diameter	1.767	1.414	1.414	0.159	0.237
SRT	2 diameter	3.142	2.513	2.513	0.503	0.562
SRS	3/8 diameter	0.110	0.078	0.078	0.000	0.003
SRS	½ diameter	0.196	0.142	0.142	0.002	0.008
SRS	5/8 diameter	0.307	0.226	0.226	0.004	0.015
SRS	3/4 diameter	0.442	0.334	0.334	0.009	0.027
SRS	7/8 diameter	0.601	0.459	0.459	0.017	0.044
SRS	1 diameter	0.785	0.606	0.606	0.029	0.067
SRS	1 1/4 diameter	1.227	0.969	0.969	0.075	0.135
SRS	1 3/8 diameter	1.485	1.155	1.155	0.106	0.175
SRS	1 ½ diameter	1.767	1.414	1.414	0.159	0.237
SRS	2 diameter	3.142	2.513	2.513	0.503	0.562

HSS = Hollow Square Section, not threaded

CHS = Circular Hollow Section – normally not threaded, therefore no section reduction

SRT= Solid Round Threaded - section reduction for threads full length

SRS= Solid Round Smooth - section reduction for coupler threads at ends

Imperial Section Properties

Type	Size	Nominal Area	Gross Area	Shear Area	M.Inertia I	Section Modulus
SRD	#6 (Diam. 3/4")	0.440	0.442	0.442	0.016	0.041
SRD	#7 (Diam. 7/8")	0.600	0.601	0.601	0.029	0.066
SRD	#8 (Diam. 1")	0.790	0.785	0.785	0.049	0.098
SRD	#9 (Diam. 1.1/8")	1.000	0.994	0.994	0.079	0.140
SRD	#10 (Diam. 1.1/4")	1.270	1.227	1.227	0.120	0.192
SRD	#11 (Diam. 1.3/8")	1.560	1.485	1.485	0.175	0.255
SRR	#4 (Diam. 1/2")	0.196	0.142	0.142	0.002	0.008
SRR	#5 (Diam. 5/8")	0.307	0.226	0.226	0.004	0.015
SRR	#6 (Diam. 3/4")	0.442	0.334	0.334	0.009	0.027
SRR	#7 (Diam. 7/8")	0.601	0.459	0.459	0.017	0.044
SRR	#8 (Diam. 1")	0.785	0.606	0.606	0.029	0.067
SRR	#9 (Diam. 1.1/8")	0.994	0.776	0.776	0.048	0.096
SRR	#10 (Diam. 1.1/4")	1.227	0.969	0.969	0.075	0.135
SRR	#11 (Diam. 1.3/8")	1.485	1.155	1.155	0.106	0.175
SRR	#12 (Diam. 1.1/2")	1.767	1.414	1.414	0.159	0.237
SRR	#16 (Diam. 2")	3.142	2.513	2.513	0.503	0.562
CRR	#8 (Diam. 1")	0.785	0.606	0.606	0.029	0.067
CRR	#9 (Diam. 1.1/8")	0.994	0.776	0.776	0.048	0.096
CRR	#10 (Diam. 1.1/4")	1.227	0.969	0.969	0.075	0.135
CRR	#11 (Diam. 1.3/8")	1.485	1.155	1.155	0.106	0.175
CRR	#12 (Diam. 1.1/2")	1.767	1.414	1.414	0.159	0.237

SRD= Solid Round Dywidag Threadbar - no section reduction at coupler

SRR= Solid Round Rebar- section reduction for coupler threads at ends

CRR= Carpenter Solid Round Rebar - section reduction for coupler threads at ends

Cintec uses Imperial dimensioned steel and components in its manufacturing for North America. When a specification is written in Metric format the nearest Imperial dimensioned product will be used. As examples, 10mm = 3/8 inch, 20mm = 3/4 inch

METRIC

Area(s) shown as square millimeters

Metric Section Properties

Type	Size	Nominal Area sq. In.	Gross Area sq. In.	Shear Area sq. In.	M.Inertia I (in.) ⁴	Section Modulus (in.) ³
HSS	25 x 25 x 3.2	261	244	98	19422	1529
HSS	32 x 32 x 3.2	343	320	136	42670	2684
HSS	38 x 38 x 3.2	424	395	174	78809	4137
HSS	50 x 50 x 3.2	586	546	249	203795	8023
HSS	50 x 50 x 4.8	832	776	334	267950	10549
HSS	35 x 64 x 6.4	1371	1279	543	679030	21387
CHS	9.5 diameter x 1.0	27	25	13	2231	470
CHS	12.7 diameter x 2.8	87	83	41	10768	1696
SRT	10 diameter	71	50	50	197	49
SRT	13 diameter	127	92	92	667	124
SRT	16 diameter	199	146	146	1702	250
SRT	19 diameter	287	217	217	3734	450
SRT	22 diameter	387	296	296	6956	717
SRT	25 diameter	507	391	391	12164	1090
SRT	32 diameter	794	627	627	31297	2215
SRT	35 diameter	957	744	744	44060	2863
SRT	38 diameter	1140	912	912	66199	3885
SRT	50 diameter	2027	1621	1621	209221	9209
SRS	10 diameter	71	50	50	197	49
SRS	13 diameter	127	92	92	667	124
SRS	16 diameter	199	146	146	1702	250
SRS	19 diameter	287	217	217	3734	450
SRS	22 diameter	387	296	296	6956	717
SRS	25 diameter	507	391	391	12164	1090
SRS	32 diameter	794	627	627	31297	2215
SRS	35 diameter	957	744	744	44060	2863
SRS	38 diameter	1140	912	912	66199	3885
SRS	50 diameter	2027	1621	1621	209221	9209

HSS = Hollow Square Section, not threaded

CHS = Circular Hollow Section – normally not threaded, therefore no section reduction

SRT= Solid Round Threaded - section reduction for threads full length

SRS= Solid Round Smooth - section reduction for coupler threads at ends

Imperial Section Properties

Type	Size	Nominal Area	Gross Area	Shear Area	M.Inertia I	Section Modulus
SRD	#6 (Diam. 19)	284	284	284	6397	673
SRD	#7 (Diam. 22)	387	387	387	11923	1074
SRD	#8 (Diam. 25)	510	507	507	20432	1609
SRD	#9 (Diam. 29)	645	642	642	32842	2297
SRD	#10 (Diam. 32)	819	794	794	50197	3157
SRD	#11 (Diam. 35)	1006	957	957	72823	4173
SRR	#4 (Diam. 13)	127	92	92	667	124
SRR	#5 (Diam. 16)	199	146	146	1702	250
SRR	#6 (Diam. 19)	284	214	214	3656	443
SRR	#7 (Diam. 22)	387	296	296	6956	717
SRR	#8 (Diam. 25)	507	391	391	12164	1090
SRR	#9 (Diam. 29)	642	501	501	20012	1584
SRR	#10 (Diam. 32)	794	627	627	31297	2215
SRR	#11 (Diam. 35)	957	744	744	44060	2863
SRR	#12 (Diam. 38)	1140	912	912	66199	3885
SRR	#16 (Diam. 50)	2027	1621	1621	209221	9209
CRR	#8 (Diam. 1")	507	391	391	12164	1090
CRR	#9 (Diam. 1.1/8")	642	501	501	20012	1584
CRR	#10 (Diam. 1.1/4")	794	627	627	31297	2215
CRR	#11 (Diam. 1.3/8")	957	744	744	44060	2863
CRR	#12 (Diam. 1.1/2")	1140	912	912	66199	3885

SRD= Solid Round Dywidag Threadbar - no section reduction at coupler

SRR= Solid Round Rebar- section reduction for coupler threads at ends

CRR= Carpenter Solid Round Rebar - section reduction for coupler threads at ends

Areas and Anchor Spacing for Domino 5 Stitching Pattern

IMPERIAL

Configuration	Diagonal Spacing	Area on Diagonal	Square Meter per Anchor	# of Anchors per Square Meter
	(in.)	(sq. in.)	(sq. in.)/Anch.	Anch./(sq. in.)
24" Vertical x 48" Horizontal.	33.9	1152	8.00	0.125
18" Vertical x 36" Horizontal.	25.5	648	4.50	0.222
16" Vertical x 32" Horizontal.	22.6	512	3.56	0.281
15" Vertical x 30" Horizontal.	21.2	450	3.13	0.320
12" Vertical x 24" Horizontal.	17.0	288	2.00	0.500

METRIC

Configuration	Diagonal Spacing	Area on Diagonal	Square Meter per Anchor	# of Anchors per Square Meter
	(mm)	(mm ²)	m ² / Anch.	Anch. / m ²
600 Vertical X 1200 Horizontal	849	720000	0.720	1.389
450 Vertical X 900 Horizontal	636	405000	0.405	2.469
400 Vertical X 800 Horizontal	566	320000	0.320	3.125
375 Vertical X 750 Horizontal	530	281250	0.281	3.556
300 Vertical X 600 Horizontal	424	180000	0.180	5.556

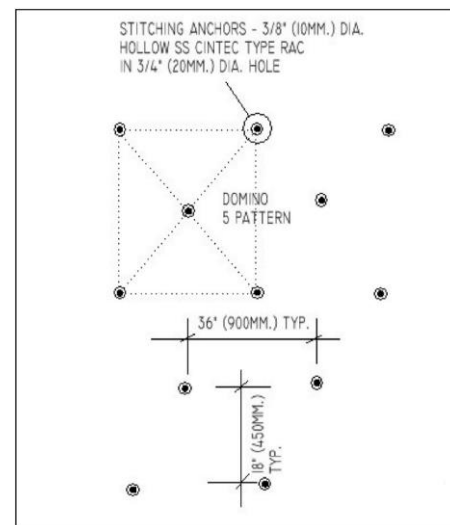

IMPERIAL - ASD

Section 4 - Design Data Section Capacities

Imperial ASD Section Design Properties

Type	Size	Type	Gross Area	Shear Area	M.Inertia I	Section Modulus
			sq. In.	sq. In.	(in.) ⁴	(in.) ³
HSS	1 x 1 x 1/8	304	Welded	1531	5068	1.671
HSS	1 1/4 x 1 1/4 x 1/8	304	Welded	2119	6634	2.918
HSS	1 1/2 x 1 1/2 x 1/8	304	Welded	2707	7417	3.844
HSS	2 x 2 x 1/8	304	Welded	3883	11333	8.744
HSS	2 x 2 x 3/16	304	Welded	5209	16101	11.511
HSS	2 1/2 x 2 1/2 x 1/4	304	Welded	8477	26536	23.342
SRT	3/8 diameter	304	UNC	893	1044	0.055
SRT	1/2 diameter	304	UNC	1587	1912	0.135
SRT	5/8 diameter	304	UNC	2480	3045	0.272
SRT	3/4 diameter	304	UNC	3571	4500	0.489
SRT	7/8 diameter	304	UNC	4861	6188	0.789
SRT	1 diameter	304	UNC	6349	8165	1.195
SRT	1 1/4 diameter	304	UNC	9920	13055	2.417
SRT	1 3/8 diameter	304	UNC	12004	15561	3.145
SRT	1 1/2 diameter	304	UNC	14285	19047	4.259
SRT	2 diameter	304	UNC	25396	33861	10.096
SRD	#6 (Diam. 3/4")	Dwyidag	UNC	11125	14881	1.860
SRD	#7 (Diam. 7/8")	Dwyidag	UNC	15171	20254	2.954
SRD	#8 (Diam. 1")	Dwyidag	UNC	19975	26454	4.409
SRD	#9 (Diam. 1.1/8")	Dwyidag	UNC	25284	33481	6.278
SRD	#10 (Diam. 1.1/4")	Dwyidag	UNC	32111	41335	8.611
SRD	#11 (Diam. 1.3/8")	Dwyidag	UNC	39444	50015	11.462
CRR	#8 (Diam. 1")	2205	UNC	15873	20412	2.988
CRR	#9 (Diam. 1.1/8")	2205	UNC	20089	26135	4.330
CRR	#10 (Diam. 1.1/4")	2205	UNC	24801	32638	6.042
CRR	#11 (Diam. 1.3/8")	2205	UNC	30009	38903	7.863
CRR	#12 (Diam. 1.1/2")	2205	UNC	35713	47618	10.648

HSS = Hollow Square Section, not threaded

SRS= Solid Round Smooth - section reduction for coupler threads at ends

SRD= Solid Round Dwyidag Threadedbar - no section reduction at coupler

CRR= Carpenter Solid Round Rebar - section reduction for coupler threads at ends

Mechanical Couplers develop the full tension and compression capacity of the net section of the anchor bodies.

Imperial ASD Section Design Properties

Type	Size	Section Type	Coupler Type	Shear Area	M.Inertia I	Section Modulus
CHS	3/8 diameter x .04	304	Welded	200	532	0.524
CHS	1/2 diameter x .11	304	Welded	646	1722	1.857
SRT	3/8 diameter	304	UNC	893	1044	0.055
SRT	1/2 diameter	304	UNC	1587	1912	0.135
SRT	5/8 diameter	304	UNC	2480	3045	0.272
SRT	3/4 diameter	304	UNC	3571	4500	0.489
SRT	7/8 diameter	304	UNC	4861	6188	0.789
SRT	1 diameter	304	UNC	6349	8165	1.195
SRT	1 1/4 diameter	304	UNC	9920	13055	2.417
SRT	1 3/8 diameter	304	UNC	12004	15561	3.145
SRT	1 1/2 diameter	304	UNC	14285	19047	4.259
SRT	2 diameter	304	UNC	25396	33861	10.096
SRR	#4 (Diam. 1/2")	304	Threadedbar	1587	1912	0.135
SRR	#5 (Diam. 5/8")	304	Threadedbar	2480	3045	0.272
SRR	#6 (Diam. 3/4")	304	Threadedbar	3571	4500	0.489
SRR	#7 (Diam. 7/8")	304	Threadedbar	4861	6188	0.789
SRR	#8 (Diam. 1")	304	Threadedbar	6349	8165	1.195
SRR	#9 (Diam. 1.1/8")	304	Threadedbar	8035	10454	1.732
SRR	#10 (Diam. 1.1/4")	304	Threadedbar	9920	13055	2.417
SRR	#11 (Diam. 1.3/8")	304	Threadedbar	12004	15561	3.145
SRR	#12 (Diam. 1.1/2")	304	Threadedbar	14285	19047	4.259
SRR	#16 (Diam. 2")	304	Threadedbar	25396	33861	10.096

CHS = Circular Hollow Section – normally not threaded, therefore no section reduction

SRT= Solid Round Threaded - section reduction for threads full length

SRR= Solid Round Rebar- section reduction for coupler threads at ends

METRIC - LRFD**Metric LRFD Section Design Properties**

Type	Size	Section Type	Coupler Type	Allowable Shear Res.	Allowable Tensile Res.	Allowable Moment Res.
	mm			N	N	N.mm
HSS	25 x 25 x 3.2	304	Welded	10275	34085	284.7
HSS	32 x 32 x 3.2	304	Welded	14268	44722	499.6
HSS	38 x 38 x 3.2	304	Welded	18198	55192	770.1
HSS	50 x 50 x 3.2	304	Welded	26120	76300	1493.6
HSS	50 x 50 x 4.8	304	Welded	35003	108352	1963.8
HSS	35 x 64 x 6.4	304	Welded	56947	178555	3981.3
CHS	9.5 diameter x 1.0	304	Welded	1620	4316	108.0
CHS	12.7 diameter x 2.8	304	Welded	5343	14236	389.7
SRT	10 diameter	304	UNC	5938	6944	9.21
SRT	13 diameter	304	UNC	10612	12782	23.0
SRT	16 diameter	304	UNC	16633	20421	46.4
SRT	19 diameter	304	UNC	24002	30244	83.7
SRT	22 diameter	304	UNC	32426	41278	133.5
SRT	25 diameter	304	UNC	42448	54586	203.0
SRT	32 diameter	304	UNC	66533	87559	412.4
SRT	35 diameter	304	UNC	80137	103889	533.0
SRT	38 diameter	304	UNC	95507	127343	723.3
SRT	50 diameter	304	UNC	169790	226387	1714.4
SRS	10 diameter	304	UNC	7331	8573	11.37
SRS	13 diameter	304	UNC	13101	15780	28.4
SRS	16 diameter	304	UNC	20535	25212	57.3
SRS	19 diameter	304	UNC	29632	37338	103.3
SRS	22 diameter	304	UNC	40032	50961	164.8
SRS	25 diameter	304	UNC	52404	67391	250.6
SRS	32 diameter	304	UNC	82140	108098	509.1
SRS	35 diameter	304	UNC	98935	128259	658.0
SRS	38 diameter	304	UNC	117910	157213	892.9
SRS	50 diameter	304	UNC	209617	279490	2116.5

HSS = Hollow Square Section, not threaded

SRT= Solid Round Threaded - section reduction for threads full length

SRS= Solid Round Smooth - section reduction for coupler threads at ends

Metric LRFD Section Design Properties

Type	Size	Section Type	Coupler Type	Shear Area	M.Inertia I	Section Modulus
SRD	#6 (Diam. 19)	DWYIDAG	UNC	91826	122179	386.9
SRD	#7 (Diam. 22)	DWYIDAG	UNC	125217	166799	617.2
SRD	#8 (Diam. 25)	DWYIDAG	UNC	164870	218351	924.4
SRD	#9 (Diam. 29)	DWYIDAG	UNC	208696	276835	1319.6
SRD	#10 (Diam. 32)	DWYIDAG	UNC	265044	342249	1813.9
SRD	#11 (Diam. 35)	DWYIDAG	UNC	325565	412230	2397.8
SRR	#4 (Diam. 13)	304	Threadedbar	13101	15780	28.4
SRR	#5 (Diam. 16)	304	Threadedbar	20535	25212	57.3
SRR	#6 (Diam. 19)	304	Threadedbar	29323	36948	101.7
SRR	#7 (Diam. 22)	304	Threadedbar	40032	50961	164.8
SRR	#8 (Diam. 25)	304	Threadedbar	52404	67391	250.6
SRR	#9 (Diam. 29)	304	Threadedbar	66440	86439	364.0
SRR	#10 (Diam. 32)	304	Threadedbar	82140	108098	509.1
SRR	#11 (Diam. 35)	304	Threadedbar	98935	128259	658.0
SRR	#12 (Diam. 38)	304	Threadedbar	117910	157213	892.9
SRR	#16 (Diam. 50)	304	Threadedbar	209617	279490	2116.5
CRR	#8 (Diam. 1")	2205	UNC	131011	168476	626.5
CRR	#9 (Diam. 1.1/8")	2205	UNC	166101	216097	910.1
CRR	#10 (Diam. 1.1/4")	2205	UNC	205350	270245	1272.7
CRR	#11 (Diam. 1.3/8")	2205	UNC	247338	320646	1644.9
CRR	#12 (Diam. 1.1/2")	2205	UNC	294774	393032	2232.3

SRD= Solid Round Dywidag Threadedbar - no section reduction at coupler

SRR= Solid Round Rebar- section reduction for coupler threads at ends

CRR= Carpenter Solid Round Rebar - section reduction for coupler threads at ends

Mechanical Couplers develop the full tension and compression capacity of the net section of the anchor bodies.

Properties of Drilled Holes – Imperial (1of 4)

HOLE DIAMETER D_h	HOLE LENGTH L_h	BOND AREA A_b (1)	BEARING AREA OF HALF CIRCUMFERENCE A_{br} (2)	SECTION MODULUS OF BEARING AREA S_{br} (3)
(in.)	(in.)	(sq. in.)	(sq. in.)	(cu. in.)
0.75	3	7.07	3.53	1.767
1	3	9.42	4.71	2.356
1.25	3	11.8	5.89	2.945
1.5	3	14.1	7.07	3.534
2	3	18.8	9.42	4.712
2.5	3	23.6	11.8	5.890
3	3	28.3	14.1	7.069
4	3	37.7	18.8	9.425
5	3	47.1	23.6	11.78
6	3	56.5	28.3	14.14
0.75	4	9.42	4.71	3.142
1	4	12.6	6.28	4.189
1.25	4	15.7	7.85	5.236
1.5	4	18.8	9.42	6.283
2	4	25.1	12.6	8.378
2.5	4	31.4	15.7	10.47
3	4	37.7	18.8	12.57
4	4	50.3	25.1	16.76
5	4	62.8	31.4	20.94
6	4	75.4	37.7	25.13
0.75	5	11.8	5.89	4.909
1	5	15.7	7.85	6.545
1.25	5	19.6	9.82	8.181
1.5	5	23.6	11.8	9.817
2	5	31.4	15.7	13.09
2.5	5	39.3	19.6	16.36
3	5	47.1	23.6	19.63
4	5	62.8	31.4	26.18
5	5	78.5	39.3	32.72
6	5	94.2	47.1	39.27
0.75	6	14.1	7.07	7.069
1	6	18.8	9.42	9.425
1.25	6	23.6	11.8	11.78
1.5	6	28.3	14.1	14.14

Properties of Drilled Holes – Imperial (2of 4)

HOLE DIAMETER D_h	HOLE LENGTH L_h	BOND AREA A_b (1)	BEARING AREA OF HALF CIRCUMFERENCE A_{br} (2)	SECTION MODULUS OF BEARING AREA S_{br} (3)
2	6	37.7	18.8	18.85
2.5	6	47.1	23.6	23.56
3	6	56.5	28.3	28.27
4	6	75.4	37.7	37.70
5	6	94.2	47.1	47.12
6	6	113.1	56.5	56.55

(1) $A_b = 3.14159 * D_h * L_h$

(2) $A_{br} = 0.5 * A_b$

(3) $S_{br} = (0.5 * 3.14159 * D_h) * (L_h ^2) * 1/6$

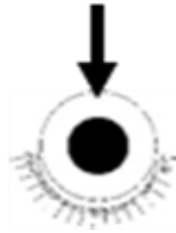

Properties of Drilled Holes – Metric (1 of 2)

HOLE DIAMETER D_h	HOLE LENGTH L_h	BOND AREA A_b (1)	BEARING AREA OF HALF CIRCUMFERENCE A_{br} (2)	SECTION MODULUS OF BEARING AREA S_{br} (3)
(mm)	(mm)	(mm ²)	(mm ²)	(mm ³)
20.0	75	4712	2356	29452
25.0	75	5890	2945	36816
32.0	75	7540	3770	47124
38.0	75	8954	4477	55960
50.0	75	11781	5890	73631
65.0	75	15315	7658	95720
75.0	75	17671	8836	110447
100.0	75	23562	11781	147262
125.0	75	29452	14726	184078
150.0	75	35343	17671	220893
20.0	100	6283	3142	52360
25.0	100	7854	3927	65450
32.0	100	10053	5027	83776
38.0	100	11938	5969	99484
50.0	100	15708	7854	130900
65.0	100	20420	10210	170169
75.0	100	23562	11781	196349
100.0	100	31416	15708	261799
125.0	100	39270	19635	327249
150.0	100	47124	23562	392699
20.0	125	7854	3927	81812
25.0	125	9817	4909	102265
32.0	125	12566	6283	130900
38.0	125	14923	7461	155443
50.0	125	19635	9817	204531
65.0	125	25525	12763	265890
75.0	125	29452	14726	306796
100.0	125	39270	19635	409061
125.0	125	49087	24544	511326
150.0	125	58905	29452	613592
20.0	150	9425	4712	117810
25.0	150	11781	5890	147262
32.0	150	15080	7540	188495
38.0	150	17907	8954	223838

Properties of Drilled Holes – Metric (1of 2)

HOLE DIAMETER D_h	HOLE LENGTH L_h	BOND AREA A_b (1)	BEARING AREA OF HALF CIRCUNFERENCE A_{br} (2)	SECTION MODULUS OF BEARING AREA S_{br} (3)
(mm)	(mm)	(mm ²)	(mm ²)	(mm ³)
50.0	150	23562	11781	294524
65.0	150	30631	15315	382881
75.0	150	35343	17671	441786
100.0	150	47124	23562	589048
125.0	150	58905	29452	736310

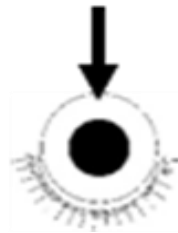

150.0	150	70686	35343	883572
-------	-----	-------	-------	--------

$$(3) A_b = 3.14159 * D_h * L_h$$

$$(4) A_{br} = 0.5 * A_b$$

$$(1) (3) S_{br} = (0.5 * 3.14159 * D_h) * (L_h ^2) * 1/6$$

Properties of Drilled Holes – Imperial (3 of 4)

HOLE DIAMETER D_h	HOLE LENGTH L_h	BOND AREA A_b (1)	BEARING AREA OF HALF CIRCUNFERENCE A_{br} (2)	SECTION MODULUS OF BEARING AREA S_{br} (3)
(in.)	(in.)	(sq. in.)	(sq. in.)	(cu. in.)
0.75	7	16.5	8.25	9.621
1	7	22.0	11.00	12.828
1.25	7	27.5	13.7	16.04
1.5	7	33.0	16.5	19.24
2	7	44.0	22.0	25.66
2.5	7	55.0	27.5	32.07
3	7	66.0	33.0	38.48
4	7	88.0	44.0	51.31
5	7	110.0	55.0	64.14
6	7	131.9	66.0	76.97
0.75	8	18.8	9.42	12.566
1	8	25.1	12.57	16.755
1.25	8	31.4	15.7	20.94
1.5	8	37.7	18.8	25.13
2	8	50.3	25.1	33.51
2.5	8	62.8	31.4	41.89
3	8	75.4	37.7	50.27
4	8	100.5	50.3	67.02
5	8	125.7	62.8	83.78
6	8	150.8	75.4	100.53
0.75	12	28.3	14.14	28.274
1	12	37.7	18.85	37.699
1.25	12	47.1	23.6	47.12
1.5	12	56.5	28.3	56.55
2	12	75.4	37.7	75.40
2.5	12	94.2	47.1	94.25
3	12	113.1	56.5	113.10
4	12	150.8	75.4	150.80
5	12	188.5	94.2	188.50
6	12	226.2	113.1	226.19
0.75	24	56.5	28.27	113.097
1	24	75.4	37.70	150.796
1.25	24	94.2	47.1	188.50
1.5	24	113.1	56.5	226.19

Properties of Drilled Holes – Imperial (4of 4)

HOLE DIAMETER D_h	HOLE LENGTH L_h	BOND AREA A_b (1)	BEARING AREA OF HALF CIRCUMFERENCE A_{br} (2)	SECTION MODULUS OF BEARING AREA S_{br} (3)
2	24	150.8	75.4	301.59
2.5	24	188.5	94.2	376.99
3	24	226.2	113.1	452.39
4	24	301.6	150.8	603.19
5	24	377.0	188.5	753.98
5.55	24	418.5	209.2	836.92

(5) $A_b = 3.14159 * D_h * L_h$

(6) $A_{br} = 0.5 * A_b$

(3) $S_{br} = (0.5 * 3.14159 * D_h) * (L_h ^2) * 1/6$



Properties of Drilled Holes – Metric (1 of 2)

HOLE DIAMETER D_h	HOLE LENGTH L_h	BOND AREA A_b (1)	BEARING AREA OF HALF CIRCUMFERENCE A_{br} (2)	SECTION MODULUS OF BEARING AREA S_{br} (3)
(mm)	(mm)	(mm ²)	(mm ²)	(mm ³)
20.0	175	10996	5498	160352
25.0	175	13744	6872	200440
32.0	175	17593	8796	256563
38.0	175	20892	10446	304669
50.0	175	27489	13744	400880
65.0	175	35736	17868	521144
75.0	175	41233	20617	601320
100.0	175	54978	27489	801760
125.0	175	68722	34361	1002200
150.0	175	82467	41233	1202640
20.0	200	12566	6283	209439
25.0	200	15708	7854	261799
32.0	200	20106	10053	335103
38.0	200	23876	11938	397935
50.0	200	31416	15708	523598
65.0	200	40841	20420	680678
75.0	200	47124	23562	785398
100.0	200	62832	31416	1047197
125.0	200	78540	39270	1308996
150.0	200	94248	47124	1570795
20.0	300	18850	9425	471239
25.0	300	23562	11781	589048
32.0	300	30159	15080	753982
38.0	300	35814	17907	895353
50.0	300	47124	23562	1178096
65.0	300	61261	30631	1531525
75.0	300	70686	35343	1767144
100.0	300	94248	47124	2356193
125.0	300	117810	58905	2945241
150.0	300	141372	70686	3534289
20.0	600	37699	18850	1884954
25.0	600	47124	23562	2356193
32.0	600	60319	30159	3015926
38.0	600	71628	35814	3581413

Properties of Drilled Holes – Metric (2of 2)

HOLE DIAMETER D_h	HOLE LENGTH L_h	BOND AREA A_b (1)	BEARING AREA OF HALF CIRCUMFERENCE A_{br} (2)	SECTION MODULUS OF BEARING AREA S_{br} (3)
(mm)	(mm)	(mm ²)	(mm ²)	(mm ³)
50.0	600	94248	47124	4712385
65.0	600	122522	61261	6126101
75.0	600	141372	70686	7068578
100.0	600	188495	94248	9424770
125.0	600	235619	117810	11780963
150.0	600	282743	141372	14137155

(7) $A_b = 3.14159 * D_h * L_h$

(8) $A_{br} = 0.5 * A_b$

(3) $S_{br} = (0.5 * 3.14159 * D_h) * (L_h ^2) * 1/6$

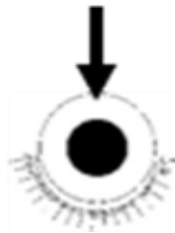

Pull out Strength of Grout Core (bond failure) Imperial ASD (1 of 2)

Hole / sock dia.	Hole / sock dia.	length (depth) of hole	A _{cyl}	Pull out capacity (ASD)
(in.)	(in.)	(in.)	(sq. in.)	(lbs.)
3/4	0.75	3	7.069	459
1	1	3	9.425	613
1 1/4	1.25	3	11.78	766
1 1/2	1.5	3	14.14	919
2	2	3	18.85	1225
2 1/2	2.5	3	23.56	1532
3	3	3	28.27	1838
4	4	3	37.70	2450
5	5	3	47.12	3063
6	6	3	56.55	3676
3/4	0.75	4	9.425	613
1	1	4	12.57	817
1 1/4	1.25	4	15.71	1021
1 1/2	1.5	4	18.85	1225
2	2	4	25.13	1634
2 1/2	2.5	4	31.42	2042
3	3	4	37.70	2450
4	4	4	50.27	3267
5	5	4	62.83	4084
6	6	4	75.40	4901
3/4	0.75	6	14.14	919
1	1	6	18.85	1225
1 1/4	1.25	6	23.56	1532
1 1/2	1.5	6	28.27	1838
2	2	6	37.70	2450
2 1/2	2.5	6	47.12	3063
3	3	6	56.55	3676
4	4	6	75.40	4901
5	5	6	94.25	6126
6	6	6	113.10	7351

Based on allowable bond stress of 65 psi (sound, solid masonry or concrete substrate) with a Factor of Safety of 4.

Pull out Strength of Grout Core (bond failure) Imperial ASD (2 of 2)

Hole / sock dia.	Hole / sock dia.	length (depth) of hole	A_{cyl}	Pull out capacity (ASD)
(in.)	(in.)	(in.)	(sq. in.)	(lbs.)
3/4	0.75	8	18.85	1225
1	1	8	25.13	1634
1 1/4	1.25	8	31.42	2042
1 1/2	1.5	8	37.70	2450
2	2	8	50.27	3267
2 1/2	2.5	8	62.83	4084
3	3	8	75.40	4901
4	4	8	100.53	6535
5	5	8	125.66	8168
6	6	8	150.80	9802
3/4	0.75	12	28.27	1838
1	1	12	37.70	2450
1 1/4	1.25	12	47.12	3063
1 1/2	1.5	12	56.55	3676
2	2	12	75.40	4901
2 1/2	2.5	12	94.25	6126
3	3	12	113.1	7351
4	4	12	150.80	9802
5	5	12	188.50	12252
6	6	12	226.19	14703
3/4	0.75	18	42.41	2757
1	1	18	56.55	3676
1 1/4	1.25	18	70.69	4595
1 1/2	1.5	18	84.82	5513
2	2	18	113.1	7351
2 1/2	2.5	18	141.4	9189
3	3	18	169.6	11027
4	4	18	226.2	14703
5	5	18	282.74	18378
6	6	18	339.29	22054

Based on allowable bond stress of 65 psi (sound, solid masonry
or concrete substrate) with a Factor of Safety of 4.

Pull out Strength of Grout Core (bond failure) Metric ASD (1 of 2)

Hole / sock dia.	Hole / sock dia.	length (depth) of hole	A_{cyl}	Pull out capacity (ASD)
(in.)	(mm)	(mm)	(mm ²)	(kN)
3/4	20	75	4712	2.11
1	25	75	5890	2.64
1 1/4	32	75	7540	3.38
1 1/2	38	75	8954	4.01
2	50	75	11781	5.28
2 1/2	65	75	15315	6.86
3	75	75	17671	7.92
4	100	75	23562	10.56
5	125	75	29452	13.19
6	150	75	35343	15.83
3/4	20	100	6283	2.81
1	25	100	7854	3.52
1 1/4	32	100	10053	4.50
1 1/2	38	100	11938	5.35
2	50	100	15708	7.04
2 1/2	65	100	20420	9.15
3	75	100	23562	10.56
4	100	100	31416	14.07
5	125	100	39270	17.59
6	150	100	47124	21.11
3/4	20	150	9425	4.22
1	25	150	11781	5.28
1 1/4	32	150	15080	6.76
1 1/2	38	150	17907	8.02
2	50	150	23562	10.56
2 1/2	65	150	30631	13.72
3	75	150	35343	15.83
4	100	150	47124	21.11
5	125	150	58905	26.39
6	150	150	70686	31.67

Based on allowable bond stress of 65 psi (sound, solid masonry or concrete substrate) with a Factor of Safety of 4.

Pull out Strength of Grout Core (bond failure) Metric ASD (2 of 2)

Hole / sock dia.	Hole / sock dia.	length (depth) of hole	A_{cyl}	Pull out capacity (ASD)
(in.)	(mm)	(mm)	(mm ²)	(kN)
3/4	20	200	12566	5.63
1	25	200	15708	7.04
1 1/4	32	200	20106	9.01
1 1/2	38	200	23876	10.70
2	50	200	31416	14.07
2 1/2	65	200	40841	18.30
3	75	200	47124	21.11
4	100	200	62832	28.15
5	125	200	78540	35.19
6	150	200	94248	42.22
3/4	20	300	18850	8.44
1	25	300	23562	10.56
1 1/4	32	300	30159	13.51
1 1/2	38	300	35814	16.04
2	50	300	47124	21.11
2 1/2	65	300	61261	27.44
3	75	300	70686	31.67
4	100	300	94248	42.22
5	125	300	117810	52.78
6	150	300	141372	63.33
3/4	20	450	28274	12.67
1	25	450	35343	15.83
1 1/4	32	450	45239	20.27
1 1/2	38	450	53721	24.07
2	50	450	70686	31.67
2 1/2	65	450	91892	41.17
3	75	450	106029	47.50
4	100	450	141372	63.33
5	125	450	176715	79.17
6	150	450	212058	95.00

Based on allowable bond stress of 65 psi (sound, solid masonry
or concrete substrate) with a Factor of Safety of 4.

Pull out Strength of Grout Core (bond failure) Imperial LRFD (1 of 2)

Hole / sock dia. (in.)	Hole / sock dia. (in.)	length (depth) of hole (in.)	A _{cyl} (sq. in.)	Pull out capacity (ASD) (lbs.)
3/4	0.75	3	7.069	778
1	1	3	9.425	1037
1 1/4	1.25	3	11.78	1297
1 1/2	1.5	3	14.14	1556
2	2	3	18.85	2075
2 1/2	2.5	3	23.56	2594
3	3	3	28.27	3112
4	4	3	37.70	4150
5	5	3	47.12	5187
6	6	3	56.55	6225
3/4	0.75	4	9.425	1037
1	1	4	12.57	1383
1 1/4	1.25	4	15.71	1729
1 1/2	1.5	4	18.85	2075
2	2	4	25.13	2767
2 1/2	2.5	4	31.42	3458
3	3	4	37.70	4150
4	4	4	50.27	5533
5	5	4	62.83	6916
6	6	4	75.40	8300
3/4	0.75	6	14.14	1556
1	1	6	18.85	2075
1 1/4	1.25	6	23.56	2594
1 1/2	1.5	6	28.27	3112
2	2	6	37.70	4150
2 1/2	2.5	6	47.12	5187
3	3	6	56.55	6225
4	4	6	75.40	8300
5	5	6	94.25	10374
6	6	6	113.10	12449

$$A_{cyl} = \pi * d_h * L_d$$

$$P_{b,Pull} = \alpha * \lambda * \phi_c * (f'_c)^{1/2} * A_{cyl}$$

Base material Strength (psi)	f _c ' =	5800
Base material factor	λ =	1
Bond resistance factor	α =	0.2
Resistance factor (for f _c ')	φ _c =	0.6

Pull out Strength of Grout Core (bond failure) Imperial LRFD (2 of 2)

Hole / sock dia. (in.)	Hole / sock dia. (in.)	length (depth) of hole (in.)	A _{cyl} (sq. in.)	Pull out capacity (ASD) (lbs.)
3/4	0.75	8	18.85	2075
1	1	8	25.13	2767
1 1/4	1.25	8	31.42	3458
1 1/2	1.5	8	37.70	4150
2	2	8	50.27	5533
2 1/2	2.5	8	62.83	6916
3	3	8	75.40	8300
4	4	8	100.53	11066
5	5	8	125.66	13833
6	6	8	150.80	16599
3/4	0.75	12	28.27	3112
1	1	12	37.70	4150
1 1/4	1.25	12	47.12	5187
1 1/2	1.5	12	56.55	6225
2	2	12	75.40	8300
2 1/2	2.5	12	94.25	10374
3	3	12	113.1	12449
4	4	12	150.80	16599
5	5	12	188.50	20749
6	6	12	226.19	24899
3/4	0.75	18	42.41	4669
1	1	18	56.55	6225
1 1/4	1.25	18	70.69	7781
1 1/2	1.5	18	84.82	9337
2	2	18	113.1	12449
2 1/2	2.5	18	141.4	15562
3	3	18	169.6	18674
4	4	18	226.2	24899
5	5	18	282.74	31123
6	6	18	339.29	37348

$$A_{cyl} = \pi * d_h * L_d$$

$$P_{b,Pull} = \alpha * \lambda * \phi_c * (f_c')^{1/2} * A_{cyl}$$

Base material Strength (psi)	f _c ' =	5800
Base material factor	λ =	1
Bond resistance factor	α =	0.2
Resistance factor (for f _c ')	φ _c =	0.6

Pull out Strength of Grout Core (bond failure) Metric LRFD (1 of 2)

Hole / sock dia.	Hole / sock dia.	length (depth) of hole	A _{cyl}	Pull out capacity (ASD)
(in.)	(mm)	(mm)	(mm ²)	(kN)
3/4	20	75	4712	3.58
1	25	75	5890	4.47
1 1/4	32	75	7540	5.72
1 1/2	38	75	8954	6.80
2	50	75	11781	8.94
2 1/2	65	75	15315	11.6
3	75	75	17671	13.4
4	100	75	23562	17.9
5	125	75	29452	22.4
6	150	75	35343	26.8
3/4	20	100	6283	4.77
1	25	100	7854	5.96
1 1/4	32	100	10053	7.63
1 1/2	38	100	11938	9.06
2	50	100	15708	11.9
2 1/2	65	100	20420	15.5
3	75	100	23562	17.9
4	100	100	31416	23.8
5	125	100	39270	29.8
6	150	100	47124	35.8
3/4	20	150	9425	7.15
1	25	150	11781	8.94
1 1/4	32	150	15080	11.4
1 1/2	38	150	17907	13.6
2	50	150	23562	17.9
2 1/2	65	150	30631	23.2
3	75	450	106029	80.5
4	100	450	141372	107
5	125	450	176715	134
6	150	450	212058	161

$$A_{cyl} = \pi * d_h * L_d$$

$$P_{b,Pull} = \alpha * \lambda * \phi_c * (f_c')^{1/2} * A_{cyl}$$

Base material Strength (Mpa)	f _c ' =	40
Base material factor	λ =	1
Bond resistance factor	α =	0.2
Resistance factor (for f _c ')	φ _c =	0.6

Pull out Strength of Grout Core (bond failure) Metric LRFD (2 of 2)

Hole / sock dia. (in.)	Hole / sock dia. (mm)	length (depth) of hole (mm)	A _{cyl} (mm ²)	Pull out capacity (ASD) (kN)
3/4	20	200	12566	9.54
1	25	200	15708	11.9
1 1/4	32	200	20106	15.3
1 1/2	38	200	23876	18.1
2	50	200	31416	23.8
2 1/2	65	200	40841	31.0
3	75	200	47124	35.8
4	100	200	62832	47.7
5	125	200	78540	59.6
6	150	200	94248	71.5
3/4	20	300	18850	14.3
1	25	300	23562	17.9
1 1/4	32	300	30159	22.9
1 1/2	38	300	35814	27.2
2	50	300	47124	35.8
2 1/2	65	300	61261	46.5
3	75	300	70686	53.6
4	100	300	94248	71.5
5	125	300	117810	89.4
6	150	300	141372	107
3/4	20	450	28274	21.5
1	25	450	35343	26.8
1 1/4	32	450	45239	34.3
1 1/2	38	450	53721	40.8
2	50	450	70686	53.6
2 1/2	65	450	91892	69.7
3	75	450	106029	80.5
4	100	450	141372	107
5	125	450	176715	134
6	150	450	212058	161

$$A_{cyl} = \pi * d_h * L_d$$

$$P_{b,Pull} = \alpha * \lambda * \phi_c * (f_c')^{1/2} * A_{cyl}$$

Base material Strength (Mpa)	f _c ' =	40
Base material factor	λ =	1
Bond resistance factor	α =	0.2
Resistance factor (for f _c ')	φ _c =	0.6

Section 4 - Design Data

What size sock can you put in a given hole diameter with a given steel size?

When the anchor is being installed in a sound and solid material then the sock diameter should match the core hole diameter. If the substrate, however, is not solid but a hollow masonry, block, terracotta or rubble filled then sometimes you may want to have a sock diameter that is larger than the hole diameter to ensure formation of a grout bulb in voids in the substrate – greatly enhancing the mechanical attachment.

NON SOLID SUBSTRATE – Holes less than 9 feet 9 inches or 3 Meters long.

SRT – Solid Round Threaded Bar	Hole Diameter	Maximum Sock Diameter
inches [mm]	inches [mm]	inches [mm]
3/8 [9.5]	1 ¼ [32]	2 [50]
1/2 [12.7]	1 ¼ [32]	2 [50]
5/8 [15.9]	1 ½ [40]	3 [75]
3/4 [19]	2 [50]	4 [100]
7/8 [22.2]	2 [50]	5 [125]
1 [25.4]	2 ½ [65]	5 [125]
1 3/8 [34.9]	3 [75]	6 [150]
1 1/2 [38.1]	3 [75]	6 [150]
2 [50.8]	4 [100]	8 [200]

Body Type	Anchor Body Size	Hole Diameter	Maximum length
	in. [mm]	in. [mm]	in. [mm]
HSS	1 x 1 [25.4 x 25.4]	2 [50]	156 [4000]
HSS	1 1/4 x 1 1/4 [31.8 x 31.8]	2 1/2 [65]	156 [4000]
HSS	1 1/2 x 1 1/2 [38.1 x 38.1]	3 [75]	156 [4000]
HSS	2 x 2 [50.8 x 50.8]	4 [100]	156 [4000]
CHS	3/8 [9.5] dia.	3/4 [19]	20 [500]
CHS	3/8 [9.5] dia.	1 [25]	40 [500]
CHS	1/2 [12.7] dia.	1 1/4 [32]	78 [2000]
SRT	3/8 [9.5] dia.	1 1/4 [32]	40 [500]
SRT	1/2 [12.7] dia.	1 1/4 [32]	40 [500]
SRT	5/8 [15.9] dia.	1 1/2 [40]	116 [3000]
SRT	3/4 [19.1] dia.	2 [50]	156 [4000]
SRT	1 [25.4] dia.	2.5 [65]	156 [4000]
SRT	1 3/8 [34.9] dia.	3 [75]	156 [4000]
SRT	1 1/2 [38.1] dia.	4 [100]	156 [4000]
SRT	2 [50.8] dia.	5 [125]	156 [4000]
SRT	3 [76.2] dia.	6 [150]	156 [4000]

Section 4 - Design Data

What is the maximum expansion of the sock into a void when grouted?

We often want to have a sock which is larger than the hole diameter to ensure formation of a grout bulb in voids in the substrate.

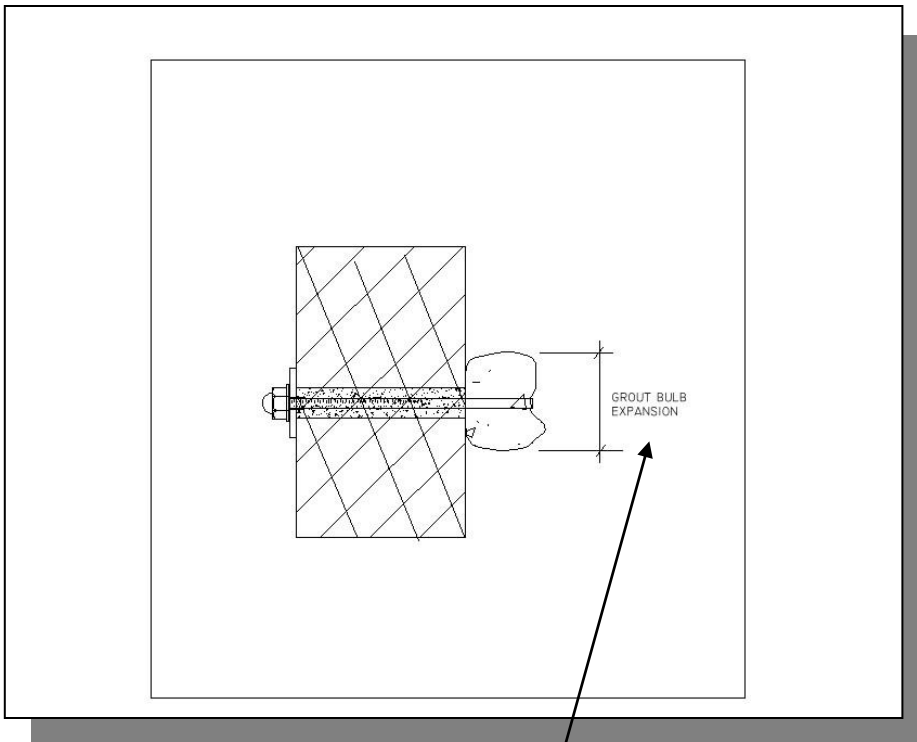

SOCK SPECIFIED DIAMETER	SOCK MAXIMUM EXPANSION DIAMETER
inches [mm]	inches [mm]
1 [25]	1 1/4 [32]
1.25 [32]	1 3/4 [45]
1.5 [38]	2 [50]
2 [50]	3 [75]
3 [75]	4 [100]
4 [100]	5 [125]
6 [150]	7 [175]

Section 4 - Design Data

What size hole is required for a given anchor size?

The minimum embedment depth of any anchor is 75mm (3") unless test anchors have been installed to determine the load achievable with a reduced embedment.

The general rule is that the bore hole must be twice the diameter of the anchor body utilised. This is only applicable up to certain lengths and the hole size must be increased on longer anchors.

The guidelines are as follows:

Body Type	Anchor Body Size	Hole Diameter	Maximum length
	in. [mm]	in. [mm]	in. [mm]
HSS	1 x 1 [25.4 x 25.4]	2 [50]	156 [4000]
HSS	1 1/4 x 1 1/4 [31.8 x 31.8]	2 1/2 [65]	156 [4000]
HSS	1 1/2 x 1 1/2 [38.1 x 38.1]	3 [75]	156 [4000]
HSS	2 x 2 [50.8 x 50.8]	4 [100]	156 [4000]
CHS	3/8 [9.5] dia.	3/4 [19]	20 [500]
CHS	3/8 [9.5] dia.	1 [25]	40 [1000]
CHS	1/2 [12.7] dia.	1 1/4 [32]	78 [2000]
SRT	3/8 [9.5] dia.	1 1/4 [32]	40 [1000]
SRT	1/2 [12.7] dia.	1 1/4 [32]	40 [1000]
SRT	5/8 [15.9] dia.	1 1/2 [40]	116 [3000]
SRT	3/4 [19.1] dia.	2 [50]	156 [4000]
SRT	1 [25.4] dia.	2.5 [65]	156 [4000]
SRT	1 3/8 [34.9] dia.	3 [75]	156 [4000]
SRT	1 1/2 [38.1] dia.	4 [100]	156 [4000]
SRT	2 [50.8] dia.	5 [125]	156 [4000]
SRT	3 [76.2] dia.	6 [150]	156 [4000]

Section 4 - Design Data

What is the hole spacing for anchors in a group?

Multiple anchors (a group) may be required to attach structural members such as shelf angles, beam brackets and pipe supports.

Anchor spacing in a group is dependent on the ability of the substrate to transfer the loads in an anchor group.

Anchor holes are typically 2 times the anchor body diameter. See the Table on Page 49 for hole sizes.

As an initial design assumption use an anchor spacing of 4 times the drilled hole diameter center to center of holes.

Section 4 - Design Data

How do we calculate bolt tension for post-tensioned applications?

Cintec anchors are tensioned by tightening the nuts to a specified torque.

The formula for torque is:

$$T = T_f \times P \times D$$

T = torque (in foot-pounds) imperial [N.m - metric];

T_f = "nut factor" or coefficient of friction (approx. value 0.0167 imperial [0.2 for metric];)

P = bolt tension in (pounds) for imperial [kN for metric];

D = bolt diameter in (inches) for imperial [mm for metric];

If embedment length is limited, how can pull out strength be increased?

T1- Example of Taper and Parallel Pull Out Loads. Cintec Anchor, 20 mm Grip Bar, 450 mm long. Rapid Grout. 06/06/02

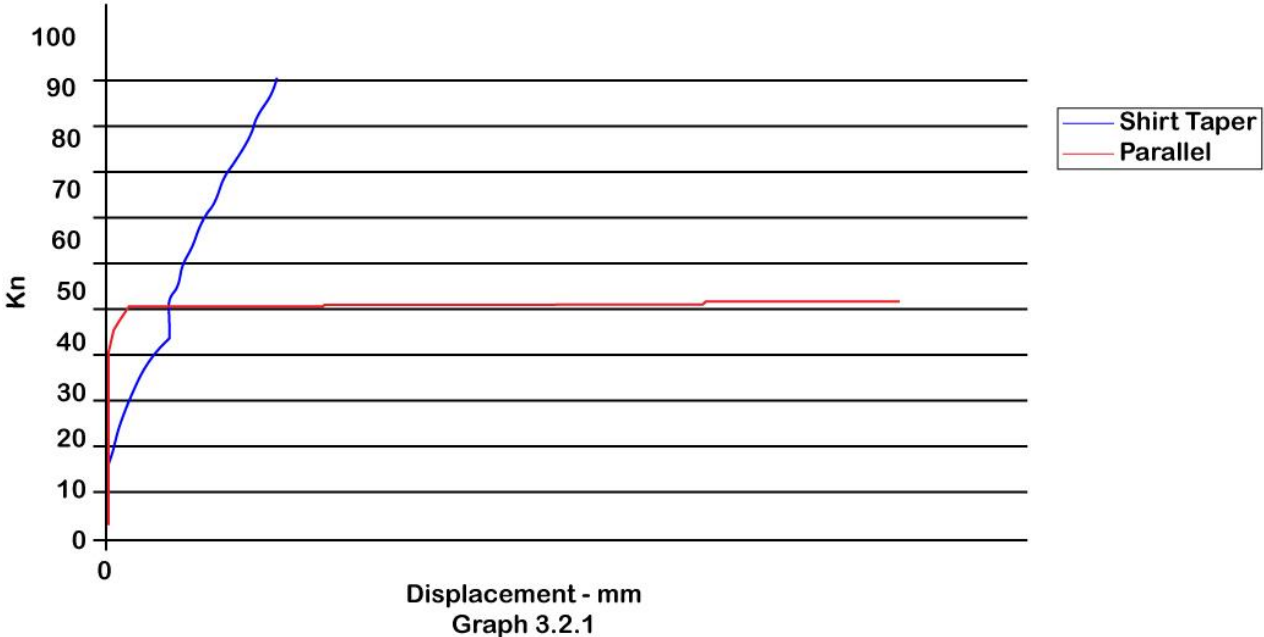

PROFILE CONFIGURATIONS

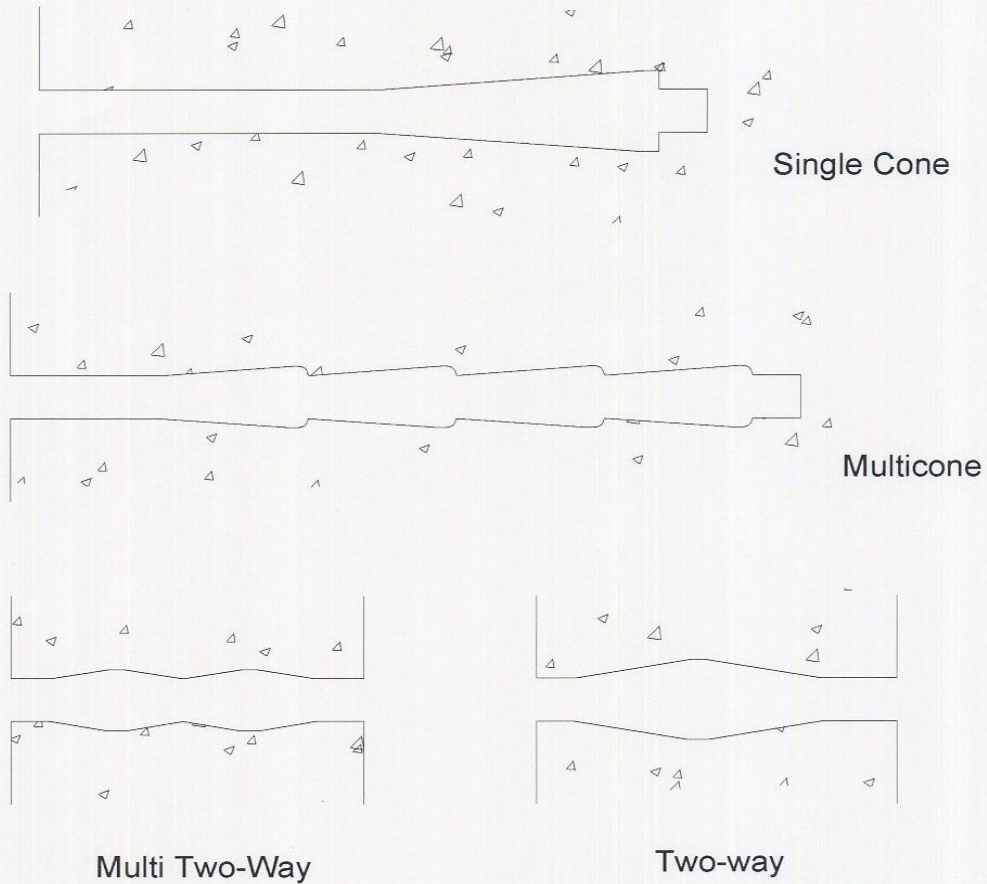

The above types of profile are offered as standard. The full cone expands to approximately 145% of nominal diameter. The multi cone is offered in lengths to suit most applications .

The two-way cone is used where anchor strength is required in both axial directions.

Variations are possible and, for further information, please contact our Engineering section.

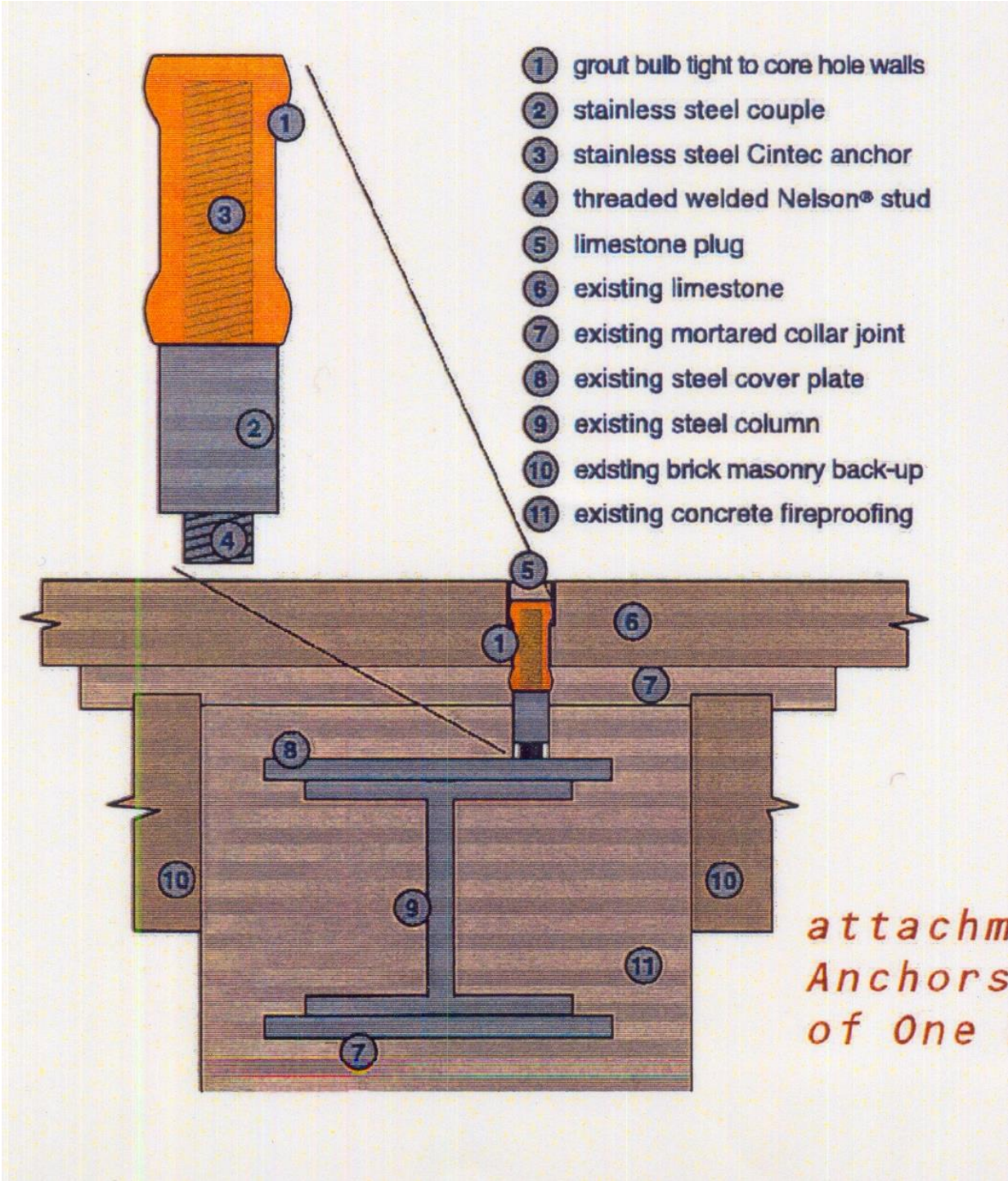

- A. Use a profiled hole using Cintec PROFILE drill bit.
- B. Attach the Cintec anchor to a steel substrate using a Nelson welded stud female ferrule.
- C. Attach the Cintec anchor to a steel substrate using a Lindapter mechanical connector.

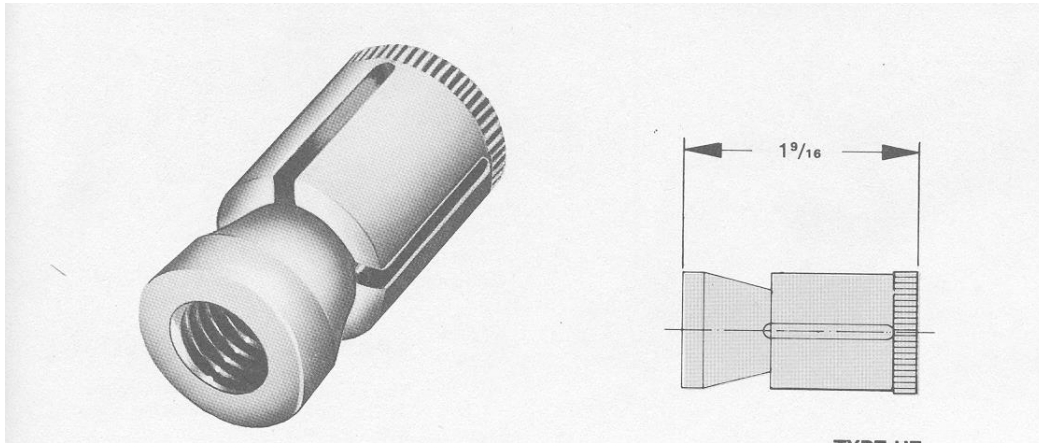

Typical Strengths of Sound Substrates.

Brick masonry

Compression at failure 2000 to 3000 psi [13.8 to 20 MPa]

Allowable bearing (crushing) 300 psi [2.06 MPa]

Allowable shear (diagonal tension) 30 psi [206 kPa]

Stone

Compression at failure up to 10,000 psi [69 MPa]

Allowable bearing (crushing) 1000 psi [6.9 MPa]

Allowable shear (diagonal tension) 30 psi [206 kPa]

Clay tile terra cotta (estimates only – very little test data is available for this material)

Compression at failure 750 to 1000 psi [6.9 MPa]

Allowable bearing (crushing) 100 psi [690 kPa]

Allowable shear (diagonal tension) 10 psi [69 kPa]

CMU concrete block

Compression at failure 1200 to 2000 psi [8.3 to 13.8 MPa]

Allowable bearing (crushing) 500 psi [3.4 MPa]

Allowable shear (diagonal tension) 30 psi [206 kPa]

Concrete

Compression at failure 3000 to 7000 psi [20 to 48 MPa]

Allowable bearing (crushing) 1000 psi [6.9 MPa]

Allowable shear (diagonal tension) 60 psi [414 kPa]

A critical step in the design process is assessment of the strength of the parent material (substrate). As this can often only be done by visual inspection of the materials, an educated estimate of the strengths of the material in-situ must be made by the design engineer.

Section 5 – Design Tools



Section Equivalent Capacities

Based on Type 304 SS material

TENSILE

TYPE	Size Diameter	Tensile (ASD)	Equivalent HSS	Equivalent CHS Diameter
	in. [mm]	lbs [kN]	in. [mm]	in. [mm]
SRT	3/8 [9.5]	1392 [6.20]	1/2 x 1/2 x 1/8 [12.7 x 12.7 x 3.2]	1/2 x 0.11 [12.7 x 2.8]
SRT	1/2 [12.7]	2610 [11.61]	1/2 x 1/2 x 1/8 [12.7 x 12.7 x 3.2]	1/2 x 0.11 [12.7 x 2.8]
SRT	5/8 [15.9]	4176 [18.58]	1 x 1 x 1/8 [25.4 x 25.4 x 3.2]	1 X 0.11 [25.4 x 2.8]
SRT	7/8 [22.2]	6090 [27.09]	1 x 1 x 1/8 [25.4 x 25.4 x 3.2]	1 X 0.11 [25.4 x 2.8]

BENDING

TYPE	Size Diameter	Bending (ASD)	Equivalent HSS	Equivalent CHS Diameter
	in. [mm]	in-lbs [kN.m]	in. [mm]	in. [mm]
SRT	3/8 [9.5]	87 [9.83]	1/2 x 1/2 x 1/8 [12.7 x 12.7 x 3.2]	1/2 x 0.11 [12.7 x 2.8]
SRT	1/2 [12.7]	209 [23.61]	3/4 x 3/4 x 1/8 [19.1 x 19.1 x 3.2]	3/4 x 0.11 [19.1 x 2.8]
SRT	5/8 [15.9]	418 [47.23]	1 x 1 x 1/8 [25.4 x 25.4 x 3.2]	1 X 0.11 [25.4 x 2.8]
SRT	7/8 [22.2]	713 [80.56]	1 1/2 x 1 1/2 x 1/8 [38.1 x 38.1 x 3.2]	1 1/2 x 0.188 [38.1 x 4.8]

Software Tools

Cintec anchors are custom made for each application. Thus, the design process does not lend itself to standardization with software.

Section 6 - Sample Specifications, Project Definitions and Details

Named Product Specification –Cintec Grout Injection Anchors Anchor System- Section 04XXX **PART 1 - Materials and Products**

1. Cementitious Injection Grout Anchors
 - .1 All anchors and Presstec grout mix shall be supplied by:
Cintec
Tel: 1-800-363-6066
Fax: 1-800-461-1862
E-mail: solutions@cintec.com
 - .2 Type of anchors to be supplied:
 - .1 Anchor Type A
Cintec Corbel Anchor
A single stage anchor with xx xx xx xx type 304 stainless steel anchor
Total length for bidding purposes is xx".
The single stage sock is to be inserted in a xx" dia hole.
 - .2 Anchor Type B
Cintec Stitching Anchor
A single stage anchor with xxx" diameter circular hollow section body
Total length for bidding purposes is xx"
The single stage sock to be inserted in a xx" diameter hole
 - .3 Anchor length shall be determined in the field before placing final order.
 - .4 Presstec Grout shall be a mineral based non-shrink grout supplied by Cintec.
Minimum 28 day compressive strength shall be 5,500 psi. The grout must have a demonstrated ability to provide the required fire resistance and 40yr durability as documented by tests of a recognized testing facility.
 - .5 The anchor system shall be designed by a Licensed Professional Engineer.

PART 2 - Installation

2. Cementitious Injection Grout Anchors
 - .1 Grout anchors shall be inserted in accordance with the manufacturer's written instructions and the project details.
 - .2 All Anchors to be installed by Cintec approved and trained contractors.
 - .3 The ends of the anchors shall be sealed with a stone or Jahn mortar plug in accordance with the project details.
 - .4 Weak Substrate
 - .1 Where a weak substrate prevents adequate bonding of the grout, the Engineer may direct that the anchor be relocated, or that the anchor hole be grooved.
 - .2 The contractor shall be paid for anchor relocation or grooving in accordance with the contract unit prices.

Generic Product Specification –Cementitious Grout Injection Anchors Anchor System- Section 04XXX

PART 1 - Materials and Products

1. Cementitious Injection Grout Anchors

.1 Anchors and grout

Design, fabrication and installation of cementitious injection grout masonry restoration anchors.

.2 Type of anchors to be supplied:

.1 Anchor Type A

Corbel Anchor

A single stage anchor stainless steel anchor

.2 Anchor Type B

Stitching Anchor

A single stage stainless steel anchor

.3 Anchor length shall be determined in the field before placing final order.

.4 Cementitious injection grout shall be a mineral based non-shrink grout supplied as supplied by the anchor system manufacturer. Minimum 28 day compressive strength shall be 5,000 psi. The grout must have a demonstrated ability to provide the required fire resistance and 40yr freeze-thaw durability as documented by tests of a recognized testing facility.

.5 The anchor system shall be designed specifically for the intended application of this project. The design shall be certified by a Licensed Professional Engineer. retained by the anchor supplier. –

PART 2 - Installation

2. Cementitious Injection Grout Anchors

.1 Grout anchors shall be inserted in accordance with the manufacturer's written instructions and the project details.

.2 All Anchors to be installed by a contractor approved and trained by the manufacturer.

.3 The ends of the anchors shall be sealed in accordance with the project details.

.4 Weak Substrate

.1 Where a weak substrate prevents adequate bonding of the grout, the Engineer may direct that the anchor be relocated, or that the anchor hole be grooved.

.2 The contractor shall be paid for anchor relocation, undercutting or grooving in accordance with the contract unit prices.

Typical Detail

Brick Stabilization – large wall area.

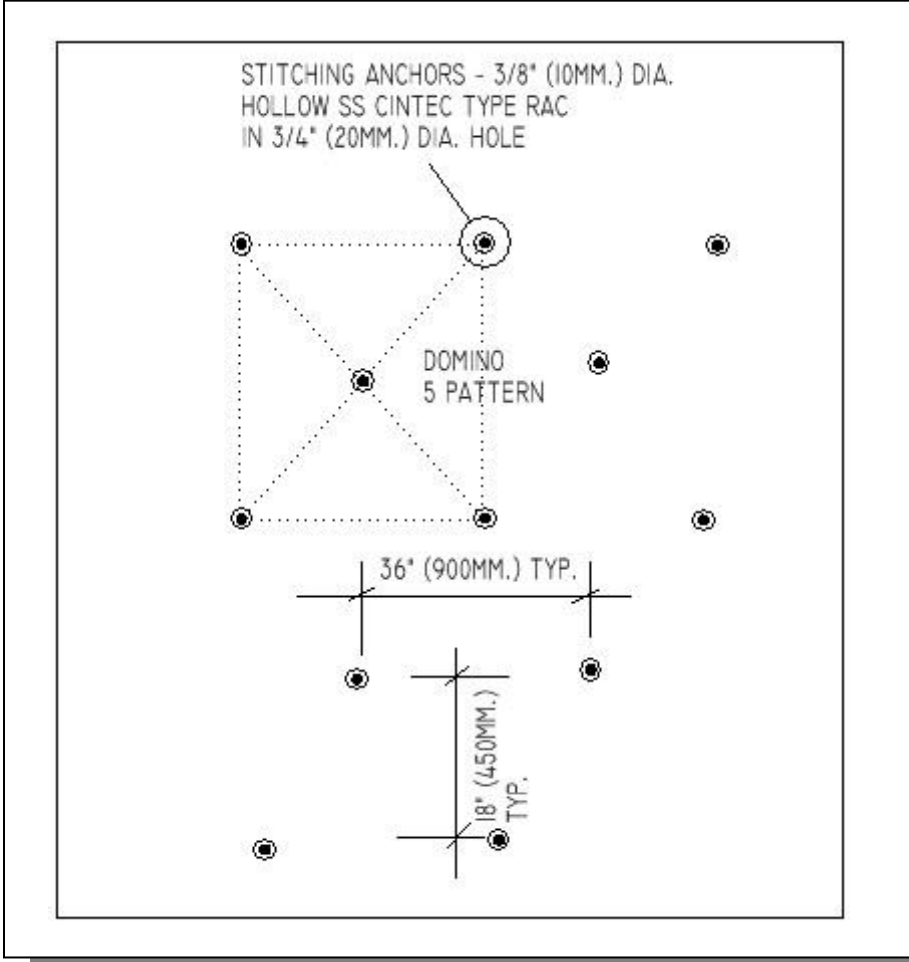

Typical Detail

Brick Stabilization – wall opening

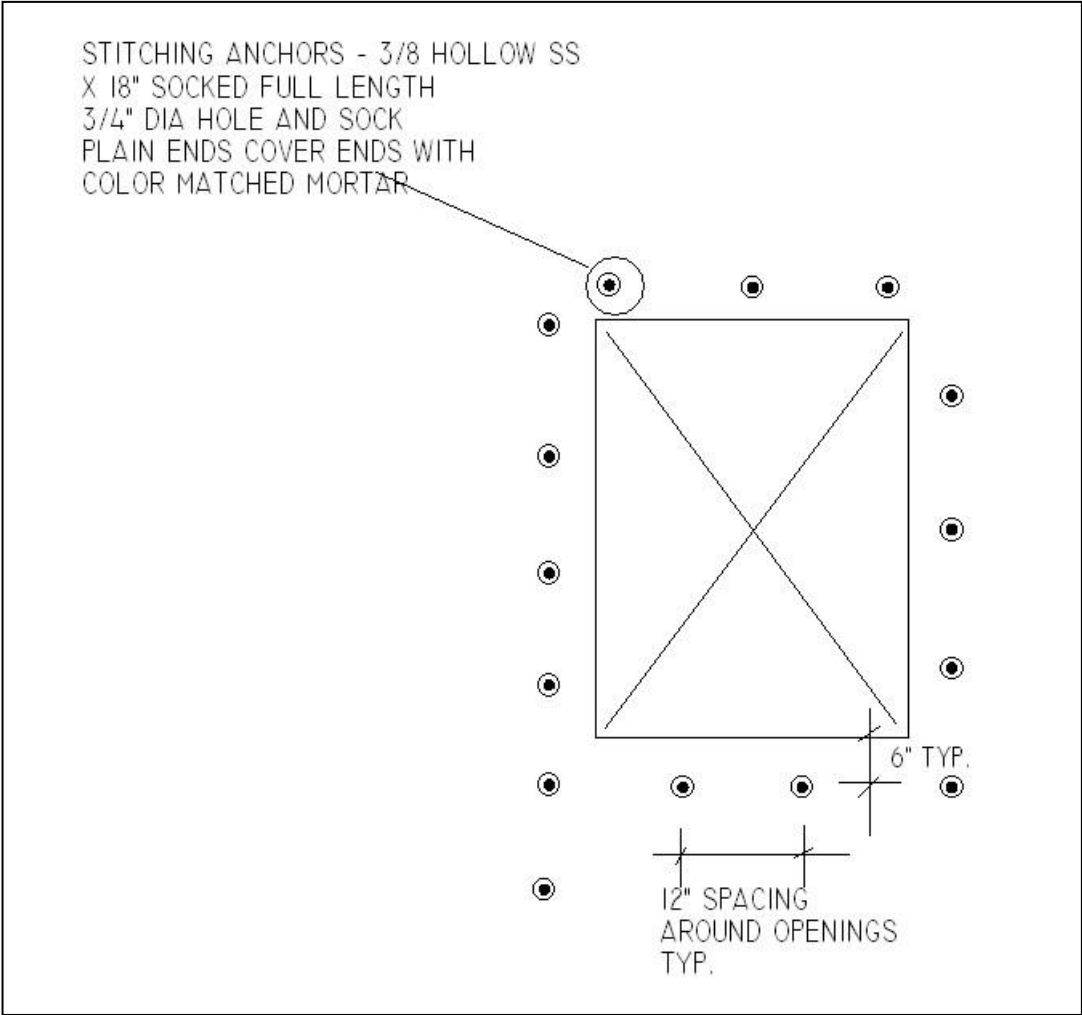

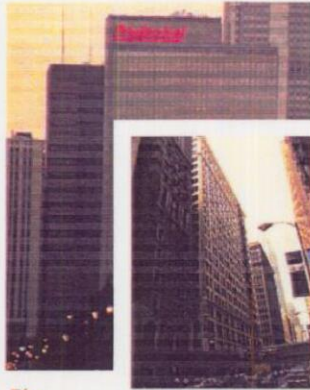

The Prudential The Chicago Building Jewellery Exchange

Stud-welded Masonry Retrofit Anchor System

Chicago, Illinois

Designed to restore lateral tieback to the supporting steel frame, the nelson® stud-welded masonry retrofit anchor has been successfully installed in repair applications to restore structural integrity to damaged or deteriorating masonry systems. Combining two diverse material technologies, Cintec's R&D department working with Boyd Associates, Inc. developed a masonry retrofit anchoring system which combines welded steel studs with the Cintec retrofit masonry anchor system.

The system is installed by first drilling small holes through the masonry to the surface of the structural steel member. A separate bit is then used to lightly mill away any surface rust or buildup on the surface of the steel member. A threaded stud is then fusion welded onto the steel member using a special adapter mounted on the standard stud gun. Following stud installation, a standard Cintec® masonry anchor with a special adapter is threaded onto the stud and completed in the standard manner.

This anchoring system has been used to restore ties to brick and terra cotta in situations which would have otherwise led to more extensive and costly removal. Applications have included both short term and permanent repair of masonry in which the original tie materials were either missing or severely deteriorated. In situations where eventual removal may take place in the future, the threaded studs can remain as the permanent structural tie for the new masonry.

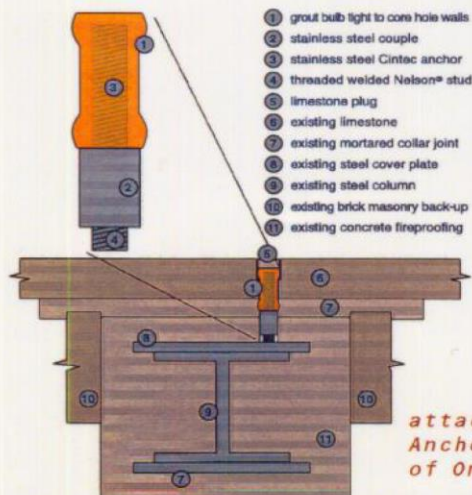

attachment of Cintec Anchors— facade repairs of One Prudential Plaza

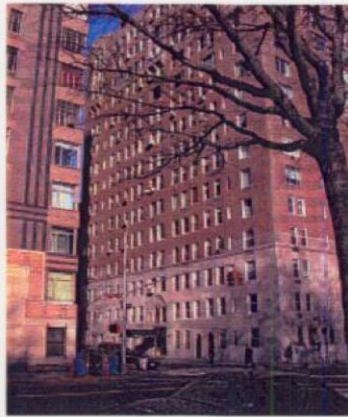

Cintec and fire rating concerns

New York, N.Y.

Howard Zimmerman Architects of New York had concerns about the lack of “fire ratings” for resin based anchor systems while performing Local Law 11 specification work on high rise apartments near Central Park. After reviewing pertinent Fire Test Data (details available upon request) and performance tests done on a severely damaged building after a fire, it was determined that the Cintec System was the best anchor to meet the project engineers' concerns.

Since Cintec's anchors are based on reliable restoration materials, cementitious grout and stainless steel, they easily provided the elusive fire rating typically absent in other systems. The Cintec Masonry Reinforcement System uses a leading edge technology, a highly flexible and durable grout control sock, to combine and transform these time tested materials into an extremely versatile repair option.

The Cintec System gives all professionals working with weakened masonry additional strengthening tools that can be easily engineered to meet specific project demands.

Cintec anchoring detail

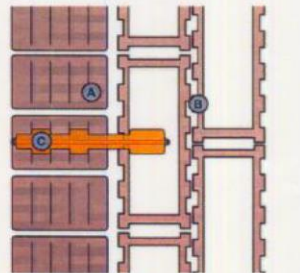

- (A) existing face brickwork
- (B) hollow cells of terra-cotta back-up masonry
- (C) Cintec anchor
3/8" (10mm) diameter,
7" (18mm) long

A Case Study



stitching corner cracks

CINTEC
NORTH AMERICA

SECURING THE PAST FOR THE FUTURE

The Problem

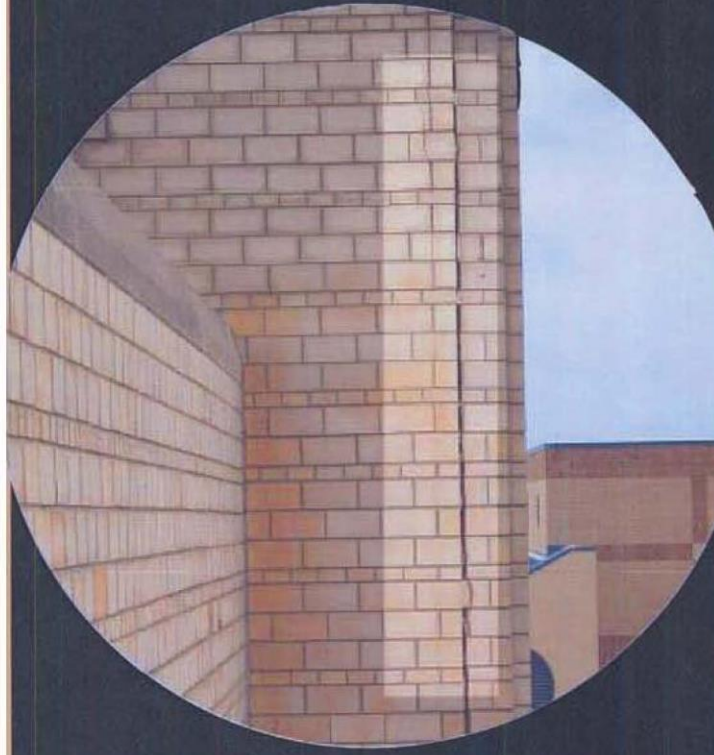

CINTEC International Limited in 1986 acquired the rights to the Cintec Anchoring System which had originally been developed in Germany.

Since then it has developed rapidly to meet the diverse requirements of the civil engineering industry in the field of strengthening and preservation.

Based in South Wales, the Company now has extensive international links with independent companies based in the United States, Canada and Australia.

The principal activity of the company is the design and manufacture of the "CINTEC" Micro Concrete and Lime Grout Anchoring and Reinforcing System.

The Standard Solution

Pros

Restores original design

Cons

time consuming | costly
problem may come back matching unit color

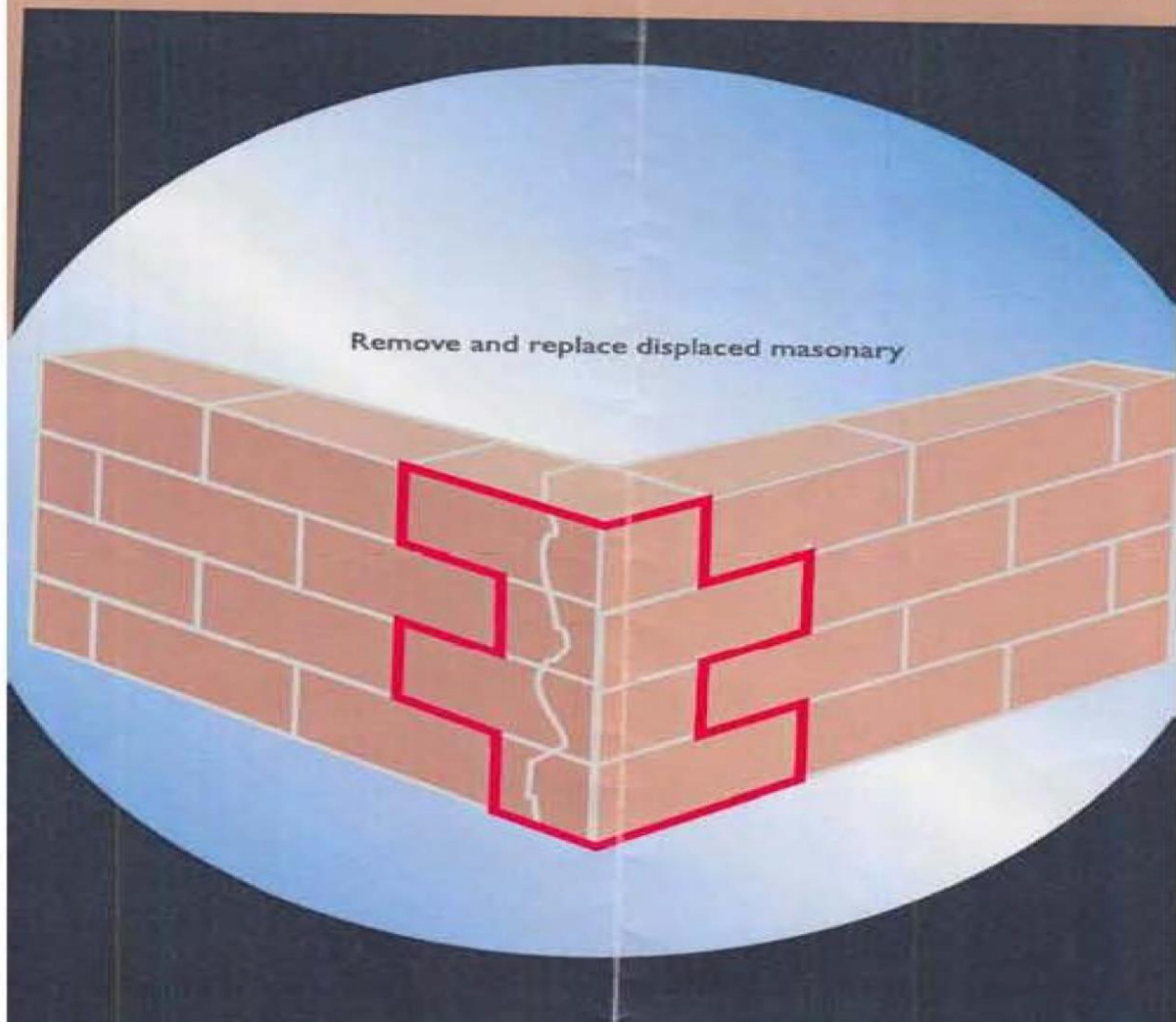

The Cintec Solution: cross corner stitching

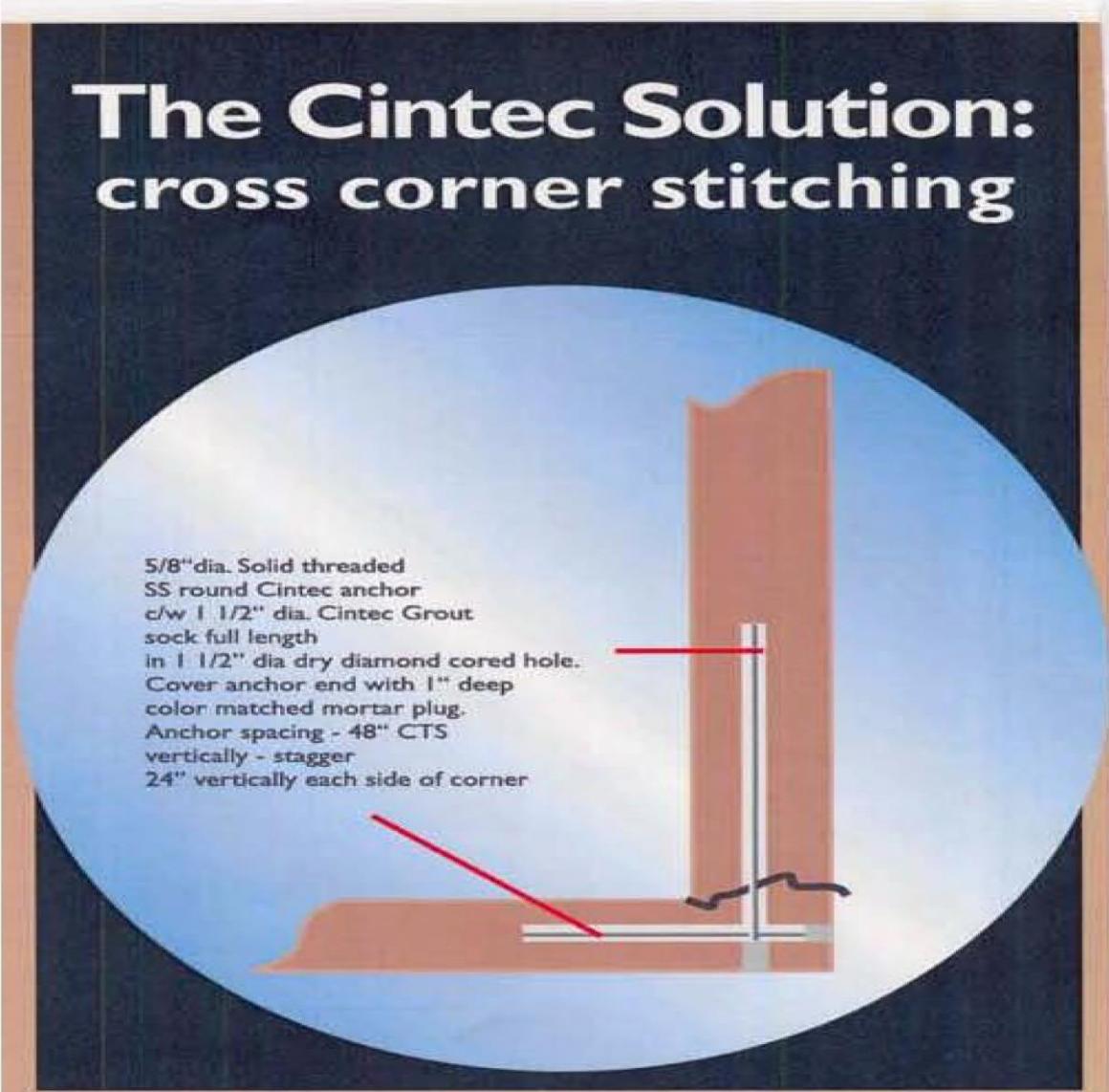

5/8" dia. Solid threaded
SS round Cintec anchor
c/w 1 1/2" dia. Cintec Grout
sock full length
in 1 1/2" dia dry diamond cored hole.
Cover anchor end with 1" deep
color matched mortar plug.
Anchor spacing - 48" CTS
vertically - stagger
24" vertically each side of corner

Pros

Cost Effective | Timely | Fireproof

Cons

Crack is stable but slightly visible

TYPICAL PROJECT DEFINITION 1

Project:

Location:

Consultant:

Problem:

The interior structure of the mill was destroyed by a fire in 1998.

The owners wish to stabilize the mill in order to preserve it as a ruin.

The roof was lost in the fire. The masonry has been exposed to the elements since the fire, without maintenance.

Probable Cause(s):

Masonry was damaged by the fire. Further deterioration has taken place since the structure was exposed to the elements. The usual masonry deficiencies are evident in photos.

Possible solutions(s):

1. Dismantle and rebuild damaged areas

Main drawback – Costly and time consuming. Difficult to obtain matching units.

2. Inject cracks with epoxy repair material.

Main drawback – Cracks may reappear at another location when similar situation occurs.

3. Install helical retrofit wall ties.

Main drawback – Helical ties are not structural repair anchors. The apparent problems appear to be structural in nature and require a structural solution.

4. Install a complete structural steel frame on the interior on new footings. This is a large-scale undertaking with budget to match.

Cintec Solution

The Cintec solution can be used to stabilize the standing masonry and facilitate installation of new masonry.

Stitching anchors will be 3/8" dia hollow stainless-steel tube in a 1" diameter hole perpendicular to the wall face. Spacing and configuration of stitching anchors shall be a diamond 5 pattern at 36" centers. Provide anchors at 18" centers around openings.

Stabilization of door and window openings shall be by Cintec structural anchors 5/8" dia. solid threaded rod in 2" dia. hole. Typical openings shall have 3 anchors vertically up from head of opening.

Large vertical cracks shall be stabilized with 5/8" diameter Cintec anchors in 2" diameter holes, spaced at 24" centers. Anchors to extend min. 24" beyond crack.

The connection of structural steel bracing members shall be by 3/4" diameter Solid threaded Cintec Anchor in 2 1/2" dia. hole.

The Cintec solution can be:

- Cost effective as the solution eliminates labor intensive operations
- Minimal intervention that is focused on areas affected by the damage
- Proven structural repair method that provides a solution engineered for conditions specific to this site.

TYPICAL PROJECT DEFINITION 2

Project:

Location:

Consultant:

Problem:

Vertical cracking occurred on the interior brick faces in the tower at the level of horizontal section change from hollow square to hollow octagonal. Cracks originate at the bottom of the windows opening and run down for approximately six feet.

Loss of exterior facing integrity that is indicated by facing stone dislocations and loss of mortar joints

Probable Cause(s):

The most likely general cause for the distress noted is water infiltration, causing internal freeze-thaw damage and/or ice lensing, gradual deterioration of stone rubble infill binding mortar and subsequent dislocations of parts of the infill. The above caused the exterior mortar joints to open encouraging farther deterioration.

Possible solutions(s):

1. Dismantle and rebuild damaged areas

Main drawback – Costly and time consuming

2. Inject cracks with repair material.

Main drawback – Cracks may reappear at another location.

3. Install retrofit wall ties and new framing

Proposed solution including Cintec Solution

Install Cintec wall repair anchors in damaged areas surround the cracks. The proposed use of Cintec Anchors is to be accompanied by grout injection into rubble infill and repairs/reinstallation of all malfunctioning exterior mortar joints

Main advantages:

- Cost effective
- Minimal intervention
- Proven structural repair method

INFORMATION REQUIRED TO DESCRIBE A CINTEC ANCHOR (IMPERIAL):

Anchor Type

A,B,C,D,etc.....

Anchor body size

5/16", 3/8" , 1/2" , 5/8", 3/4" , 7/8" 1" , 1 1/4" , 1 3/8" , 1 1/2" , and 2" (dia.)Anchor body shape

1. CHS - Circular Hollow Section
2. HSS - Hollow Square section
3. SRD - Solid round DYWIDAG Threadbar
4. SRT - Solid round threaded
5. SRR - Solid Round Rebar
6. SRS - Solid Round Smooth Bar
7. CRR- Carpenter Solid Round Rebar

Anchor Body material

1. Stainless Steel (SS)*

Stainless steel type

1. ANSI Type 304*
2. ANSI Type 316
3. ASTM 276 Carpenter 2205
4. ASTM A564 17-4 CF Bar

Anchor body overall length

1. xx"

Hole Size

1. xx" diameter.

Anchor body end

1. Plain end
2. Nut and washers
3. Nut washers and end plate (describe size, shape, thickness and material of end plate)

Grout sock size

1. xx" diameter sock
2. Sock expands to yy" dia. in voids

Sock length

1. Full length
2. Overall length minus xx" (leaving enough thread exposed to make end connections)
3. Sock length plus exposed threaded length.

Anchor end covers (when plain end anchor is used)

1. Color (color) matched mortar plug
2. Stone core plug
3. Exposed

Configuration

1. xx" diamond 5 pattern (standard diamond 5 pattern size is 36")
2. Specify spacing

Notes

Contractor to confirm length in the field before ordering. *

Example:

Anchor Type A

3/8" dia. solid round threaded SS ANSI Type 304 Cintec Anchor

x 24" long socked 18" with 6" exposed threads /w 2 ' 1/2" dia. sock in 1 1/2" dia. hole
c/w nut, washers and 2" x 2" x 1/2" sq. plate.

INFORMATION REQUIRED TO DESCRIBE A CINTEC ANCHOR (METRIC):

Anchor Type

A,B,C,D,etc.....

Anchor body size

7.9 mm, 9.5 mm, 12.7 mm, 15.9 mm, 19.1 mm, 22.2 mm, 25.4 mm, 31.8 mm, 34.9 mm, 38.1 mm, and 50.8 mm (Anchor body shape)

1. CHS - Circular Hollow Section
2. HSS - Hollow Square section
3. SRD - Solid round DYWIDAG Threadbar
4. SRT - Solid round threaded
5. SRR - Solid Round Rebar
6. SRS - Solid Round Smooth Bar
7. CRR- Carpenter Solid Round Rebar

Anchor Body material

1. Stainless Steel (SS)*

Stainless steel type

1. ANSI Type 304*
2. ANSI Type 316
3. ASTM 276 Carpenter 2205
4. ASTM A564 17-4 CF Bar

Anchor body overall length

1. xx"

Hole Size

1. xx" diameter.

Anchor body end

1. Plain end
2. Nut and washers
3. Nut washers and end plate (describe size, shape, thickness and material of end plate)

Grout sock size

1. xx" diameter sock
2. Sock expands to yy" dia. in voids

Sock length

1. Full length
2. Overall length minus xx" (leaving enough thread exposed to make end connections)
3. Sock length plus exposed threaded length.

Anchor end covers (when plain end anchor is used)

2. Color (color) matched mortar plug
2. Stone core plug
3. Exposed

Configuration

1. xx" diamond 5 pattern (standard diamond 5 pattern size is 900 mm)
2. Specify spacing

Notes

Contractor to confirm length in the field before ordering. *

Example:

Anchor Type A

9.5 mm dia. solid round threaded SS ANSI Type 304 Cintec Anchor

x 609.6 mm long socked 457.2 mm with 152.4 mm exposed threads /w 63.5 mm dia. sock in 38.1 mm

dia. Hole

c/w nut, washers and 2" x 2" x 1/2" sq. plate.

CALCULATION OF ANCHOR DESIGN

Refer to Cintec Engineering Manual

Read pages 17, 18 as general introduction.

Determine application: Is the anchor to act as a:

- A - Stitching anchor for brick or masonry (usually CHS but may be SRT for higher loads)
- B - Wall reinforcing anchor (usually SRT but may be HSS)
- C - Wall anchor used for attaching to something i.e.: header, beam etc. (usually SRT but end treatments can be defined by Engineer/ Architect)

Determine loads to be placed on the anchor.

- A - Shear
- B - Tensile
- C - Bending Moment
- D - Pull Out (bond failure)

Substrate capacity will usually be less than designed anchor capacity.

Wall (substrate) thickness must be determined as anchor lengths are predicated on this information. Stitching anchors are usually 4" [100 mm] less in length than total wall thickness (embed length). Anchors used for attaching are usually wall thickness less 2" [50 mm] (embed length) plus the amount of protrusion needed for end treatment.

Page 22 – Locate stainless steel configuration (CHS, HHS or SRT) and pick size from table so that all values equal or exceed determined loads.

Page 30 – Hole diameter selected from table based on style and diameter of steel to be used. (Note length limitations)

Page 26, 27 – Using the embed lengths and hole diameter previously found locate corresponding Pull Out Strength. Straight extrapolation for longer lengths is acceptable. If pull out is less than needed, diameter of cored hole may be increased.

The above is a good general determination of anchor needs. I should also caution you that any load other than direct tension pull out should be looked at by a Cintec engineer. A second opinion never hurts.

Preliminary Design Input Form
CINTEC Anchoring Systems

Project : _____ Location : _____
Consultant: _____ Owner: _____
Contractor: _____
Contact Person: _____ FAX: _____ Tel: _____
E-mail: _____ Representing: _____

Loads: Units: _____
Unfactored (WSD / ASD) : YES / NO
Factored (USD or LFRD): YES / NO
Vertical: Down: _____ eccentricity: _____
Up: _____ eccentricity: _____

Lateral: Pull Out: _____
Compression: _____
Horizontal: _____

Anchor Design Mechanism: _____ (e.g. : straight pullout , direct tension, double curvature flexure, single curvature flexure, shear, eccentric bracket/corbel)

Materials

Anchor Body: _____ type spec.: _____
Substrate: _____ type
_____ condition
_____ strength of material

Cintec sock: _____ type (e.g.: expanding, oversize, 2 stage, full length)
Grout : Presstec 5000psi [35MPa] ultimate

Load Free Body Diagram :

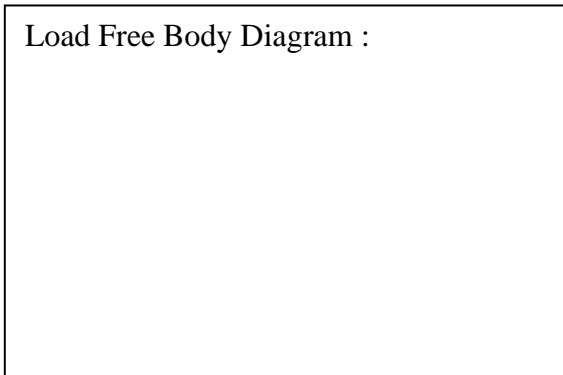

Cross Section Detail :

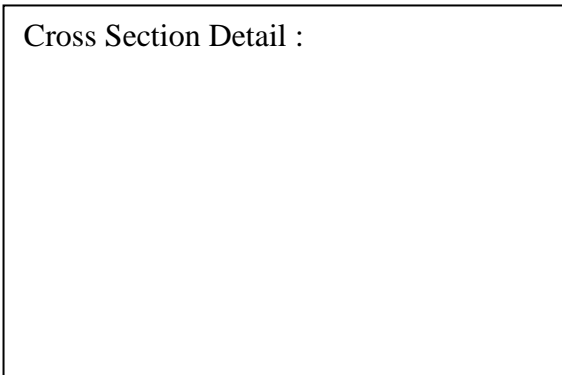

Submit Design request to:
Cintec Attn: Engineering Department
Fax: 1 800 461 1862 or e-mail: engineering@cintec.com

Digital or scanned photos, ACAD drawings and copies of historic drawings will greatly assist in providing a Cintec Solution.
CINTEC GROUTED ANCHOR SYSTEMS

Anchor Design and Selection Matrix

Project: xxx
 Anchor Type or Group: xxx
 Anchor System or Manufacturer: xxx
 Submittal Date: xxx

Level	Component Group	Element	Data Source	Applicable Standards and Specs	Submittal ID/date	Submittal and Data sufficient to evaluate	More data or submittals required	What additional data or submittals are required?	Evaluation Pass / Fail	Is Evaluation fail fatal?	Remarks
Level 1	Technical Assessment										
	Anchor body	compatibility with other anchor components corrosion resistance yield strength - mill test certificates roughness for bond to Bonding Medium freeze-thaw lead tests fire resistance warranty design support and technical literature load capacity per anchor minimum intervention reversibility load transfer between Bonding Medium, anchor body and substrate licensing and certification of installers seismic retrofit									
	System										
	Substrate	does anchor induce new stresses in the substrate (e.g. wedge anchors) compatible with Bonding Medium previous relevant experience with this substrate									
	Experience	does advertising and marketing material mention this type of application relevant experience - substrate relevant experience - years relevant experience - geographic references check - solicited and unsolicited material type percent stretch if applicable permeability where does Bonding Medium flow damage to substrate consolidation effective in various humidity levels elastic creep characteristics freeze-thaw absorption chemical composition compatibility with anchor body and substrate shrinkage characteristics compression strength strength gain time cyclical force resistance for seismic can it be done dry damage to substrate can drill equipment be supported independently from the building can hazard and dust be captured can hole be profiled or roughened if required ease of load and proof testing during the flow of the work how to assure bond on required bond length licensing, training and certification of installers									
	Bonding Medium Retention										
	Bonding Medium										
	Drilling										
	Quality Assurance										
Level 2	Contractual Assessment										
		schedule impact delivery logistics cost impact proven JIT delivery experience									

This anchor selection matrix is particularly useful in obtaining sole source approval for specifying Cintec with government agencies.

Technical Bulletin No. 1

Retrofit Wall Ties.

One of the most common applications of Cintec Anchors is as a retrofit wall tie. These are usually installed on a domino 5 pattern with an 18" x 36" [450 x 900 mm] spacing.

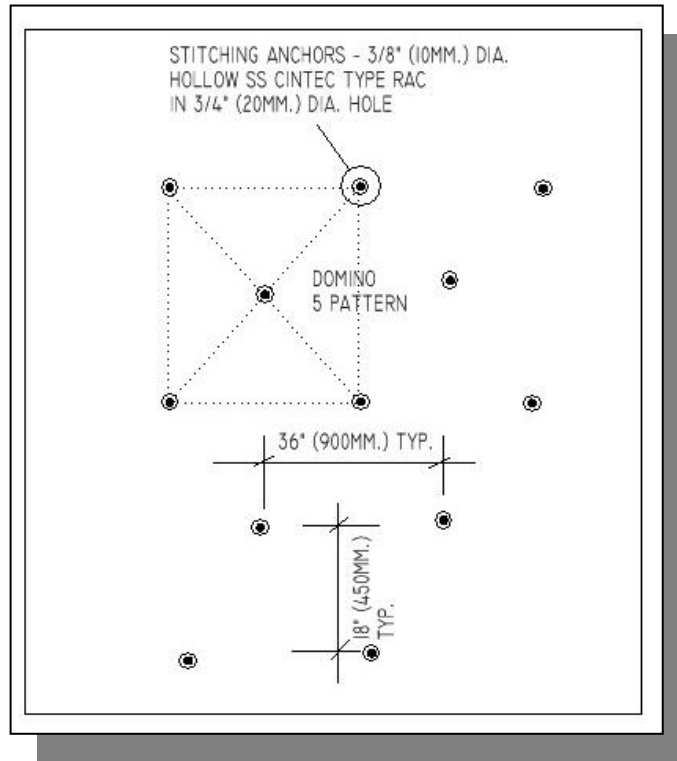

The typical anchor is an RAC type with Type 304 Stainless Steel 3/8" [9.5 mm] diameter hollow round section with 0.04" [1.0 mm] thick wall. This anchor is installed in a 3/4" [20 mm] diameter hole with a 3/4" [19.1 mm] sock. The embedment length of the grouted sock is typically 3" [75 mm] less than the overall wall thickness. (2" inches [50 mm] cover at far end of anchor, 1" [25 mm] cover at near end).

One of the most common technical queries we receive is:

“The spacing of the wall ties does not appear to meet all codes.
Can you provide background to assist in approvals?”

The model North American building codes require that wall ties for brick or stone veneers be spaced 16” x 24” [400 x 600 mm] centers horizontal or vertical.

This is based on a traditional approach where thin metal ties are attached to wooden or steel wall studs at either 24” [600 mm] or 16” [400 mm] centers. The overall spacing is determined by the pull-out capacity of the wood screw attaching the brick tie to the wall stud. The required and supplied pull out strength is approximately 80 pounds [356 N] (unfactored).

This approach has little relevance to a retrofit wall tie in an historic or modern masonry wall system. The 18” x 36” [450 x 900 mm] spacing recommended for Cintec Retrofit ties provides a pull-out resistance of at least 325 pounds [1.45 kN] (unfactored). The required resistance, even at a rather high wind suction of 50 pounds (unfactored) per square foot of wall surface [2.4 kPa], is 225 pounds [1.0 kN] (unfactored). Note that Cintec anchor designs are typically based on a factor of safety of 4.0.

The other consideration in selecting anchor spacing is the allowable distance between lateral supports. This spacing in model North American Codes, is 20 times the thickness of the wythe being tied. Using a 3 5/8” [92.1 mm] thick brick, this yields a minimum distance between ties of 72” [1829 mm]. The typical Cintec retrofit tie system provides a maximum spacing of 25” [635 mm], 33% of the allowable.

European model building codes are recognizing the need to apply sound engineering principles to the design of refit solutions for masonry walls. The British Standard requirements for ties in existing masonry walls uses the domino 5 pattern and similar spacing to that recommended by Cintec.

Prepared by:

Cintec North America
15 March 2005

Cintec – Technical Bulletin No. 2

Application: Brick Veneer reattachment to wood frame or steel stud back up wall.

Building Deficiency: Brick ties have corroded through or were not installed.

Process:

- drill 1" [25.4 mm] diameter hole through brick,
- a protective plastic sleeve is inserted
- slide anchor into the sleeve
- drill anchor into metal or wood stud or sheathing using a drill and nut driver.
- inject the anchor through the hollow end with cementitious grout
- cover anchor end with a color matched patching mortar (Jahn or Edison)



Cintec Technical Bulletin No. 3

The flush connection of structural members to walls or girders.

There are several methods to accomplish this with Cintec structural anchors.

Generally, the Cintec anchors will be the SRT type with a minimum diameter of 5/8" [16 mm]. The material can be any type of stainless steel that is available in the required profiles.

There are several methods for accomplishing this. It is important to have accurate durable templates of the face of the connecting members.

Option 1 involves:

- drill 2 holes for each anchor in the connecting member, one for the anchor body, 1/8" [3.2 mm] in diameter greater than the anchor, and a second hole for the grout feed tube.
- pre drill the holes in the substrate,
- insert anchor in the holes and align with the template
- inject the anchors
- place the connecting plate or bracket over the anchors and install nuts and washers.

Option 2, the preferred option is:

- drill holes in the connecting member, sufficiently large to be able to install anchors through the holes
- drill the holes in the substrate to the required diameter and length
- hold connecting members in place
- insert anchors in the hole
- place a donut washer in the hole over the anchors. This washer shall have the 2 holes as described in Option 1. The washer shall be 1/16" [1.6 mm] dia smaller than the hole in the connecting plate and of the same thickness as the connecting plate.
- place the connecting plate or bracket over the anchors
- inject the anchors
- install nuts, washers and a loose cover plate.

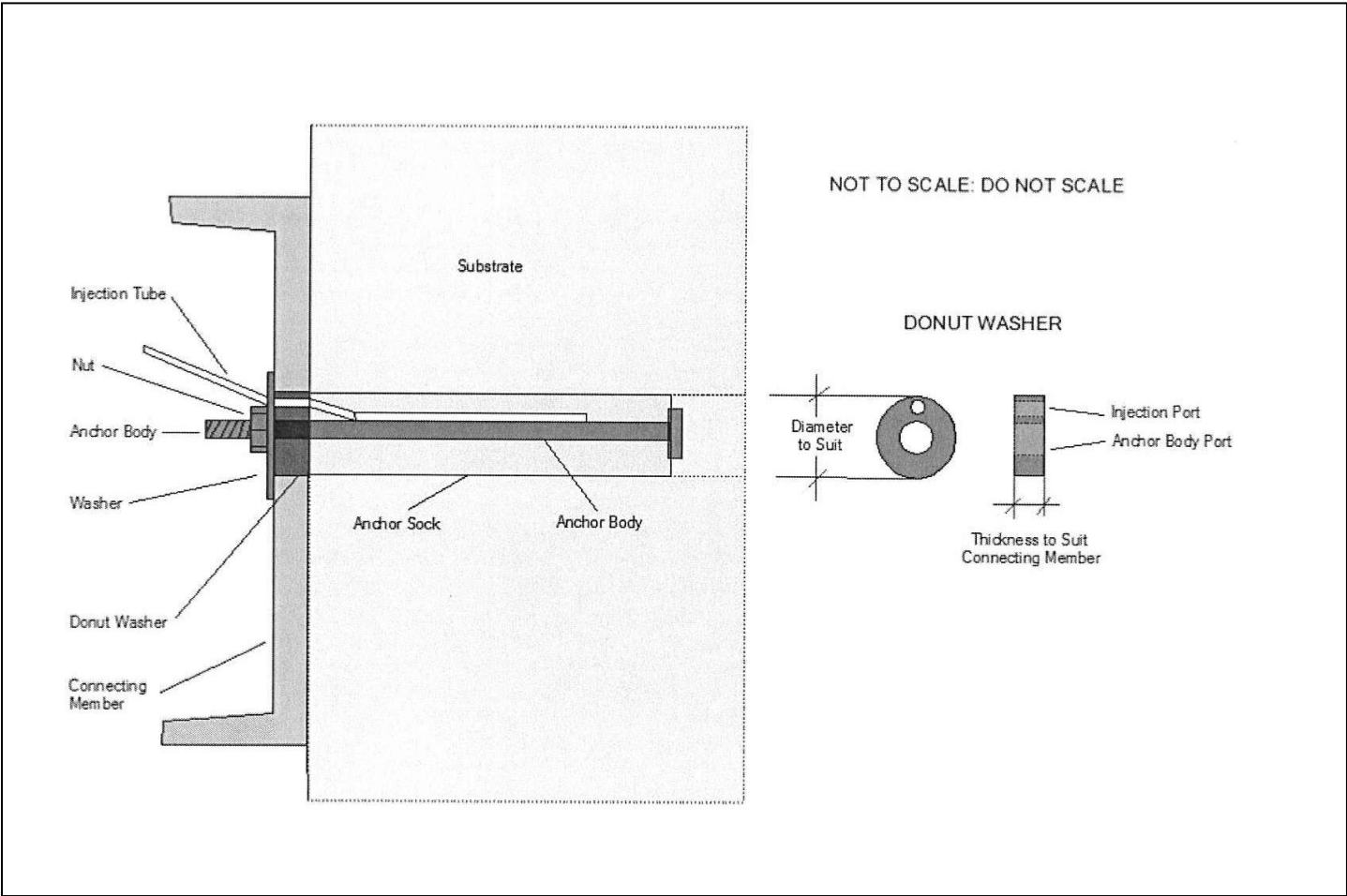

Cintec Technical Bulletin No. 4

Timber Frame Repairs

Cintec structural reinforcement anchors can be used to repair mortise and tenon joints in timber structures.

The Cintec group bulb is non-absorbent and thus is not subject to freeze thaw action nor does it retain moisture that can contribute to rotting in the wood.

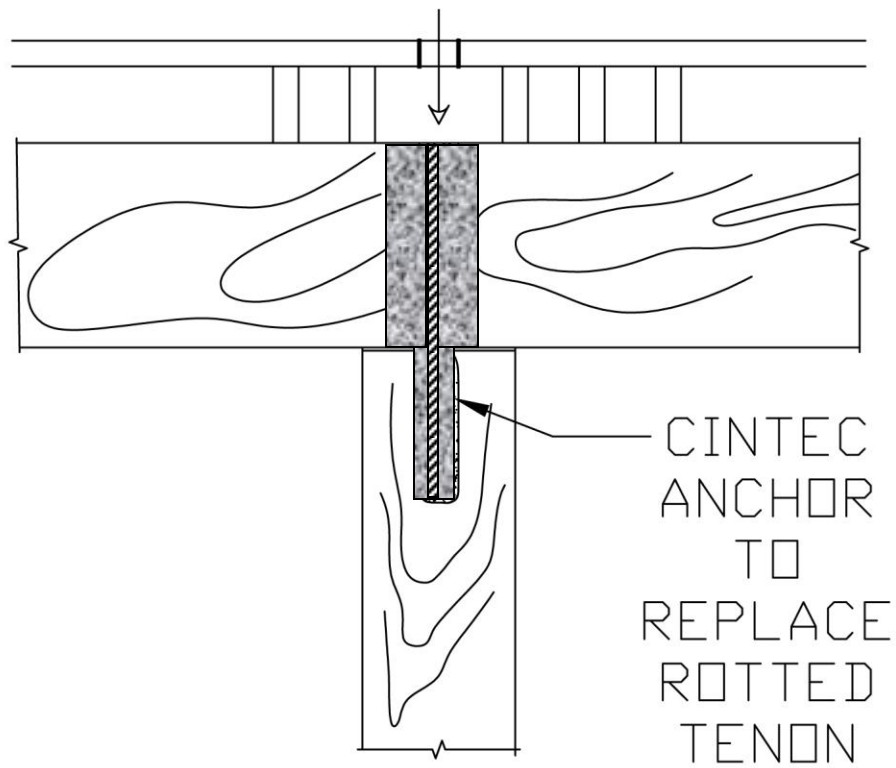

Technical Bulletin 5

Progressive Collapse.

The best defense against progressive collapse of structures in events such as blasts or earthquakes is to tie the main members together. Cintec can do this for a number of different types of structural materials, unobtrusively.

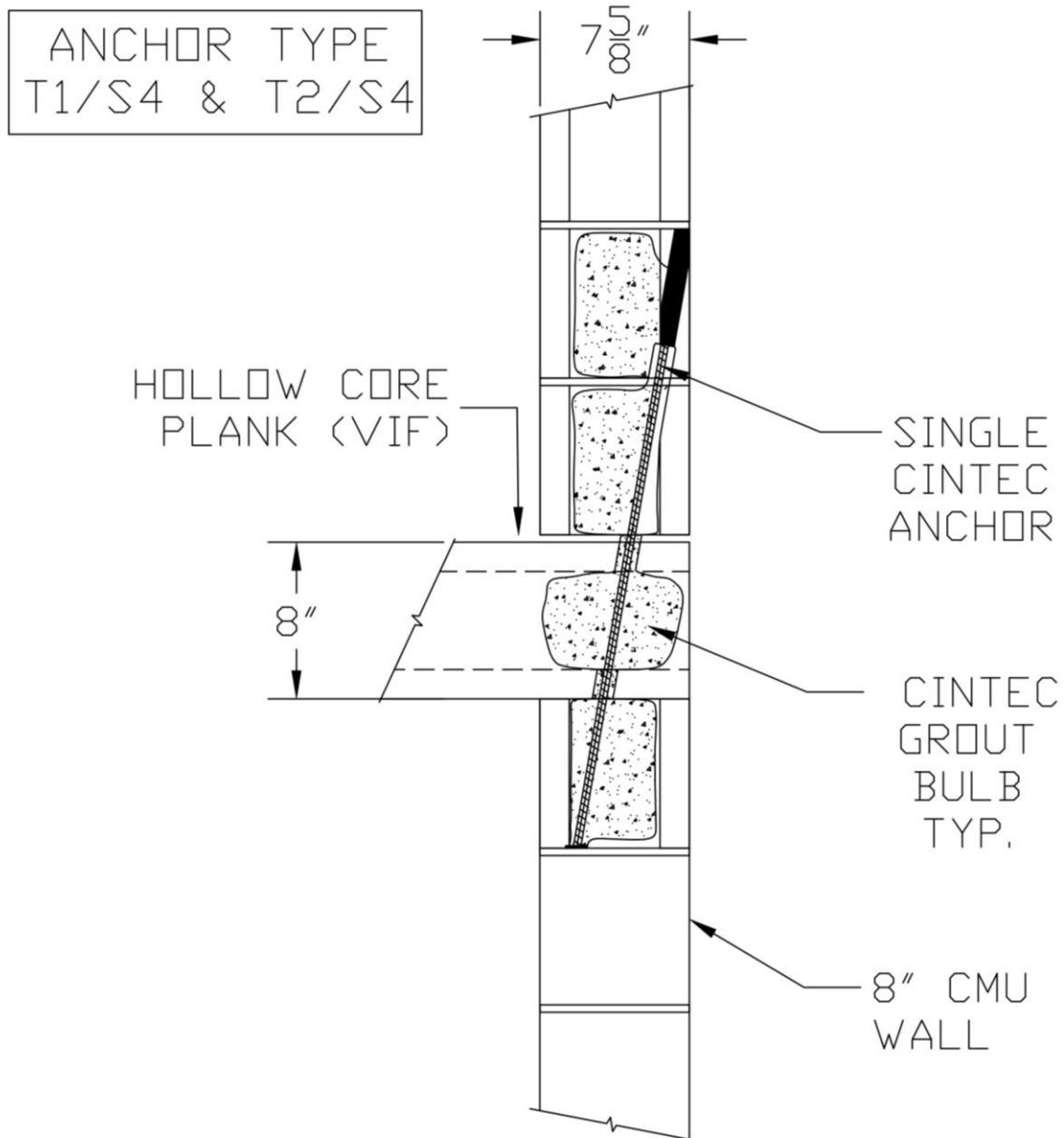

Technical Bulletin 6

Blast Protection

As mentioned previously Cintec has applications to mitigate progressive collapse. One aspect of blast protection where Cintec excels is in connection of blast resistant window frames to the main building fabric. The effectiveness of these anchors has been proven in full scale blast tests.

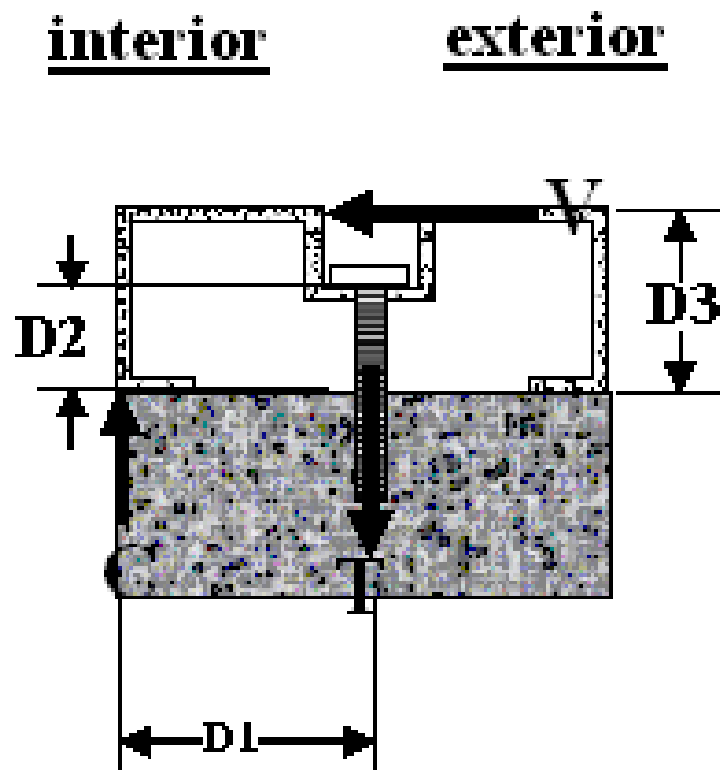

Cintec Technical Bulletin No. 7

Post-Tensioned Masonry

A two stage Cintec anchor can be used to overcome the inherent inability of masonry construction to take tensile stresses.

The first stage is anchored in a solid substrate below the member being reinforced.

Typical applications are parapets, guardrails, statuary.

It is possible to eliminate, the intrusive corrosion prone steel bracing with its penetrations of waterproofing membranes.

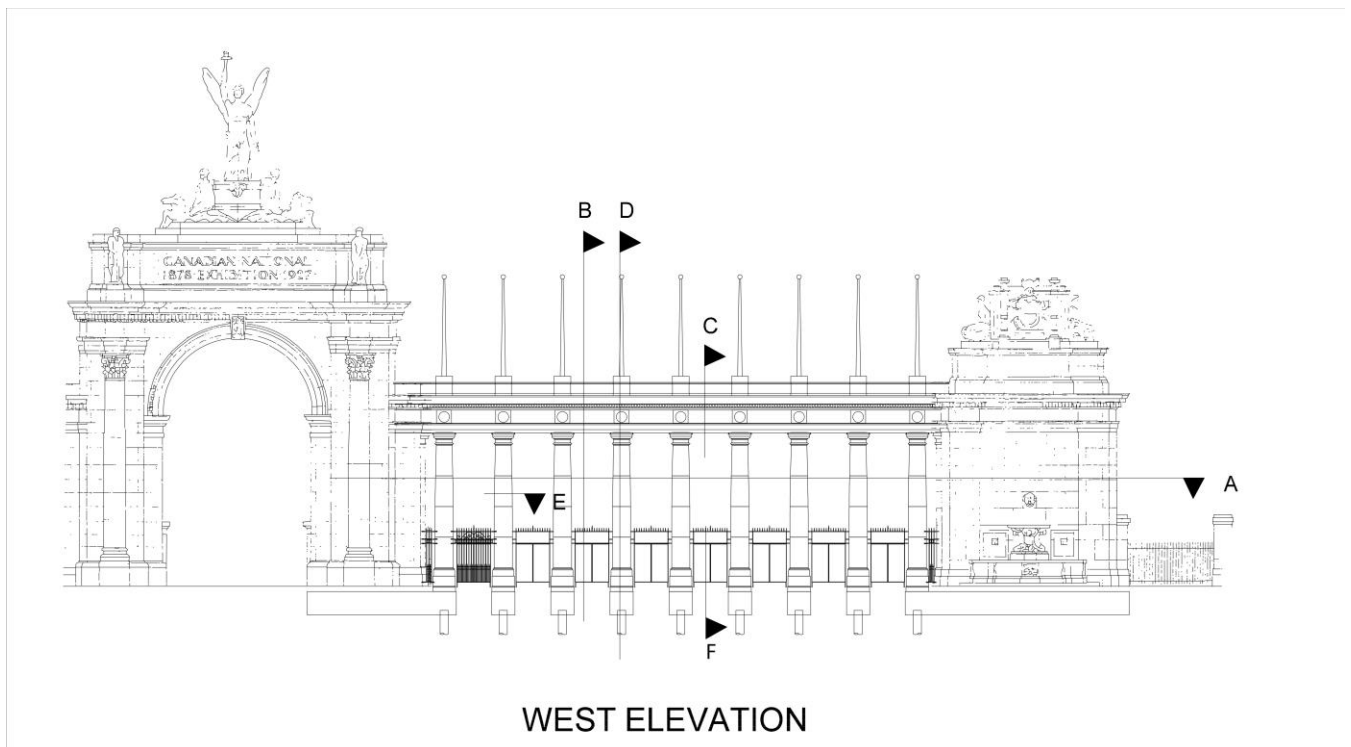

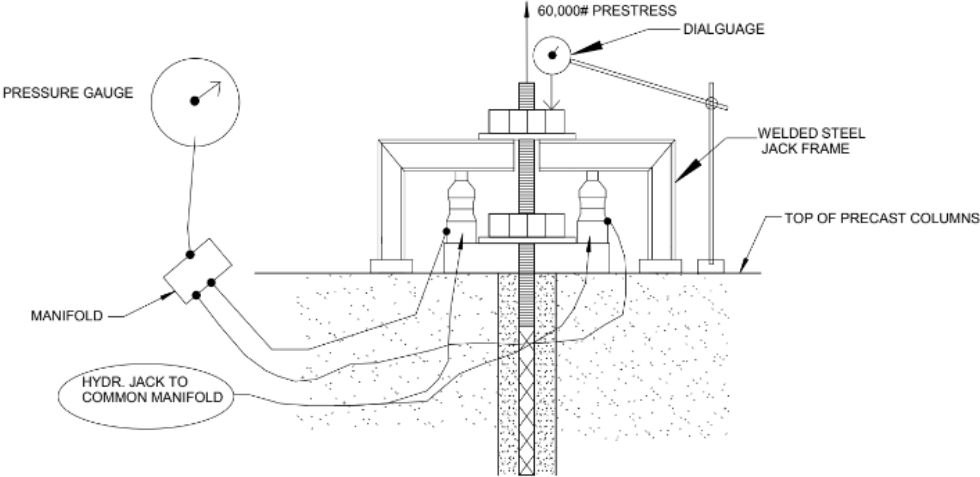

POST-TENSIONING RIG

C
C
S

Section 7 – Installation Drilling and Quality Assurance

Installation

Installation is done by persons trained and certified by Cintec. Companies are not certified, only their personnel. Normally the firm doing the drilling also undertakes the installation.

Drilling

Drilling can be the biggest challenge in an anchoring project. Not just any drilling firm can do drilling in sensitive structures. Surprisingly, the softer and looser the substrate the harder the drilling. Soft and loose material falls into the core and binds the drill bit, with resultant loss of the bit and productivity, A new core must be started.

Cintec recommends that in masonry all drilling be done with non-percussive drilling. This is a recommendation only and NOT mandatory to Cintec installation.

Water cooled and percussive drilling can be done in harder substrates such as rock and concrete.

Methods are available to drill through contaminated spaces and materials where hazmat such as asbestos may be present. The drill dust can be captured with a rubber boot apparatus at the entry hole attached to a HEPA filtered vacuum

It is always recommended that the drill rigs be firmly attached to rigid supports such as scaffold. Hand drilling is not recommended.

With experienced drillers, holes of over 100 feet in length to very tight lateral tolerances can be obtained. Cintec may be able to refer drillers and installers for specific projects in your area.

Quality Assurance

The main components of the Cintec system, stainless steel and cementitious grout, are manufactured under strict quality assurance systems. The assembly of these components is done in a Cintec owned and operated shop.

Quality assurance in the field is assured by the installer training and certification process noted above.

Section 8 – Sustainable Design

The main components of Cintec anchors are stainless steel and a cementitious grout. Both of these materials require considerable energy to create and by themselves have a high carbon footprint.

However, they are used in minimal quantities during the conservation, repair and preservation of structures.

The underlying principle of preservation is “minimal intervention”. The Cintec Solutions certainly support this concept. In fact, Cintec is often referred to as the keyhole surgery for buildings in distress.

The alternative to the Cintec solution is usually tear down and replace, be it the entire structure or parts thereof. This approach is the worst scenario from an environmental point of view. All of *the embodied energy* in the structure is lost when this approach is used.

Wikipedia states:

Embodied Energy is the sum of all the energy required to produce goods or services, considered as if that energy was incorporated or 'embodied' in the product itself. The concept can be useful in determining the effectiveness of energy-producing or energy-saving devices (does the device produce or save more energy that it took to make it?), of buildings, and, because energy-inputs usually entail greenhouse gas emissions, in deciding whether a product contributes to or mitigates global warming.

Section 9 - Special Applications

Seismic - SEISTEC

Cintec's seismic upgrading system is called SEISTEC.

Cintec anchors utilizing a combination of hollow sections and solid round sections are used to provide internal reinforcement to masonry structures at risk in seismic zones.

The approach can be both reactive and proactive. Earthquake damaged structures can be restored without major dismantling.

Existing structures not yet damaged by seismic events can be reinforced to withstand anticipated seismic loads.

The basic approach is to tie the main lateral force resisting elements together. Buildings in active seismic zones have already demonstrated an ability to resist seismic loads. The insertion of new stiff elements such as shearwalls or frames may alter significantly the established load paths, leading to failure of critical elements and inappropriate transfer of loads to (and from) the foundations.

The Cintec Seismic Solution reinforces and ties together the existing elements. Schematic details illustrating the approach follow.

Cintec anchors are useful in reinforcing architectural elements such as parapets and attachment of OFC's.

The seismic solution also provides a measure of protection against blast loads and progressive collapse.

Seismic design is a complex process. It is recommended that the designer of such projects wishing to assess the feasibility of a Cintec application contact Cintec at an early stage in the project. Cintec retains independent engineers experienced in seismic retrofit, particularly in historic masonry structures to provide assistance to project engineers.

Typical Cintec Seismic Interventions

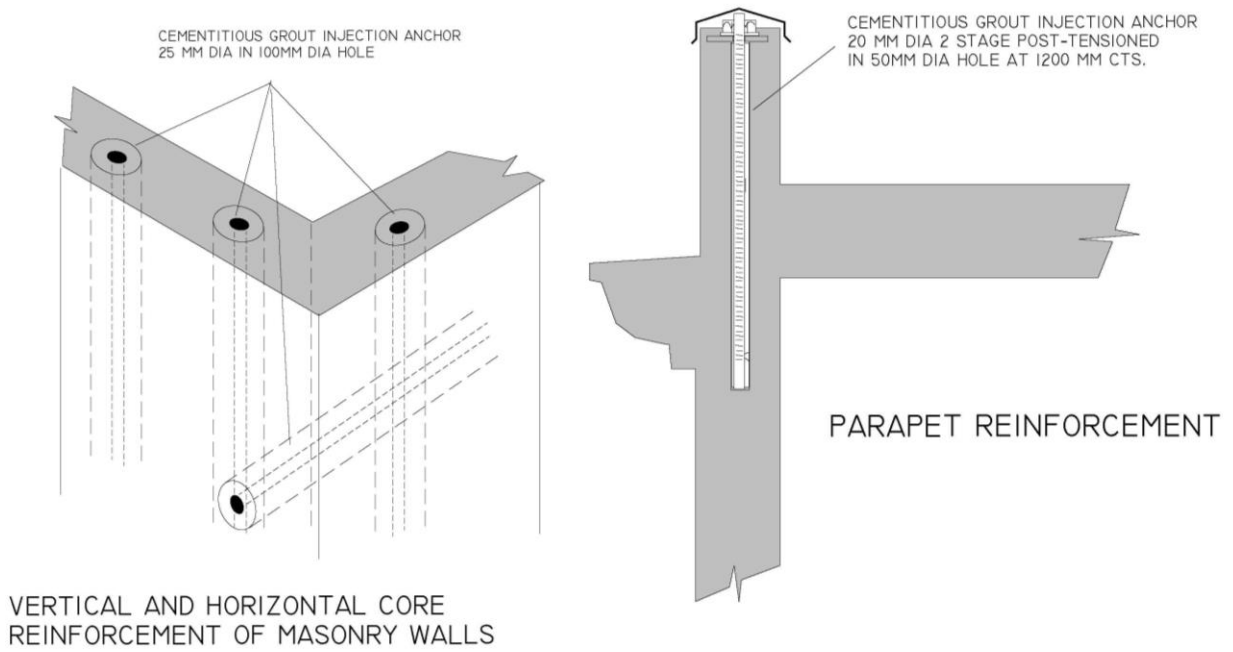

Typical Cintec Seismic Interventions

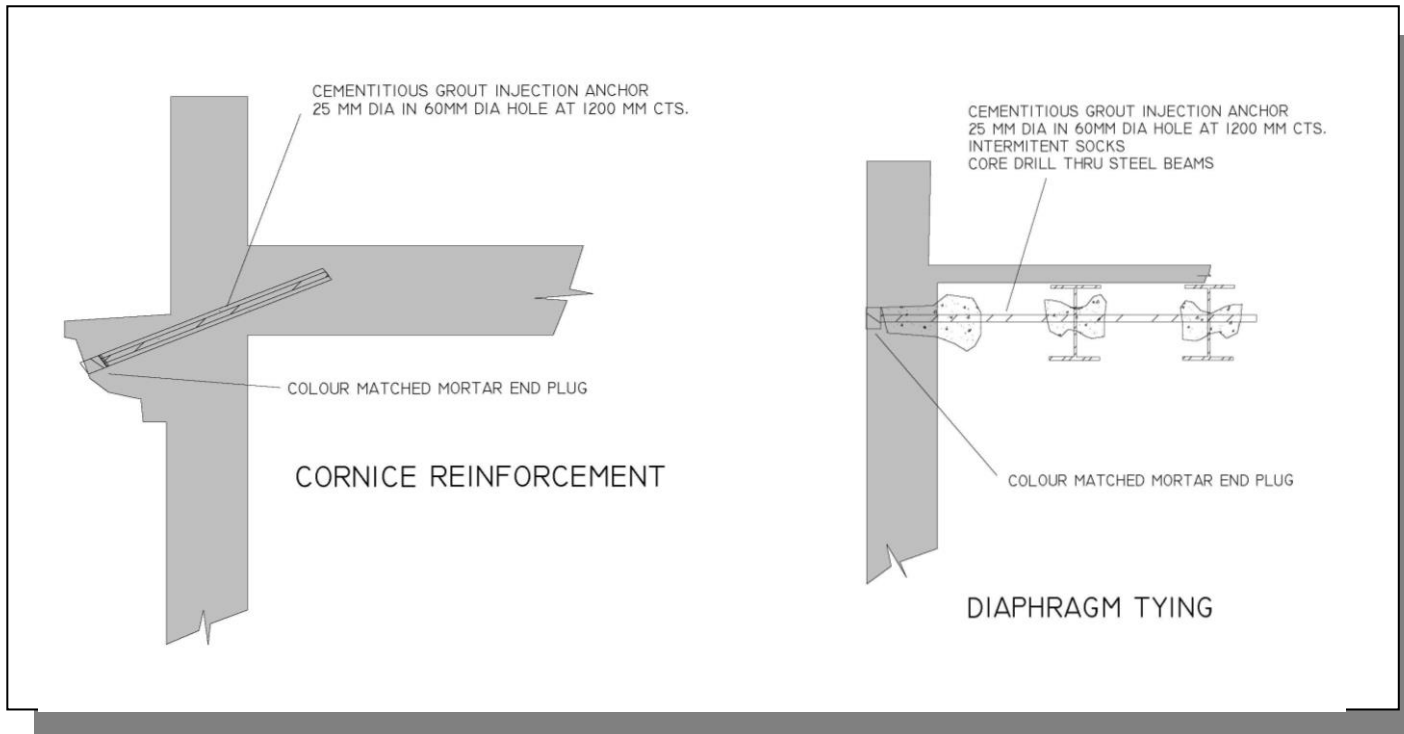

Typical Cintec Seismic Interventions

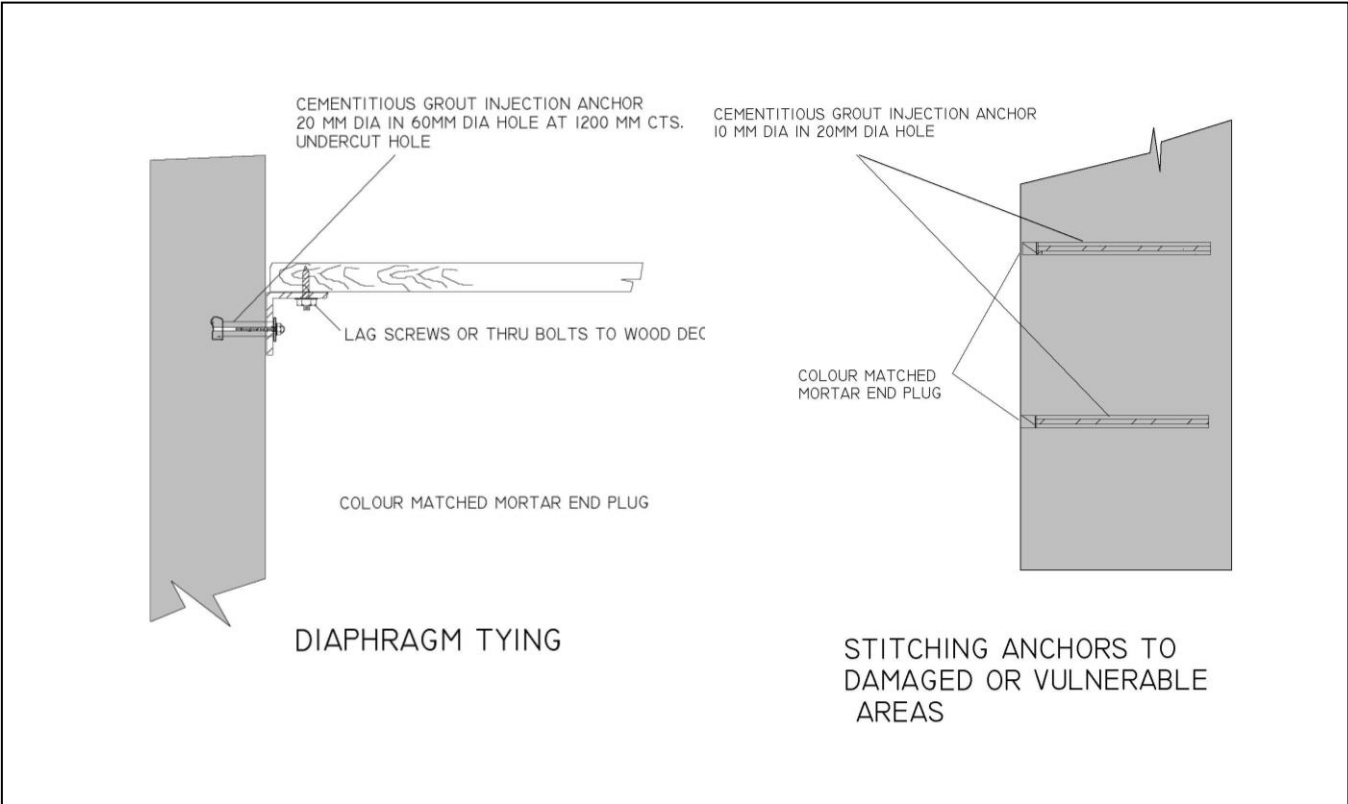

Blast Protection - BLASTEC

Cintec's blast protection upgrading system is called BLASTEC.

Cintec anchors utilizing a combination of hollow sections and solid round sections are used to provide internal reinforcement to masonry structures at risk of exposure blast loads.

The approach can be either reactive or proactive. Blast damaged structures can be restored without wholesale dismantling.

Existing structures not yet damaged by blast events can be reinforced to withstand anticipated explosive loads.

The basic approach is to tie the main lateral force resisting elements together, and to tie architectural elements such as windows to the surrounding building elements.

The Cintec Blastec Solution reinforces and ties together the building elements. Schematic details illustrating the approach follow.

The Blastec solution also contributes to protection against seismic loads and progressive collapse.

The Cintec Blast Solution provides a good measure of protection against post-blast intrusion in the event of terrorist attack.

Design for blast loads is a complex process. It is recommended that the designer of such projects wishing to assess the feasibility of a Cintec application contact Cintec at an early stage in the project. Cintec retains independent blast engineers and structural engineers experienced in blast retrofit, particularly in historic masonry structures, to provide assistance to project engineers.

Blast requirements for GSA Level **C** blast protection can generate loads up to 4 psi (576 psf) of window area.

Level **D** protection yields loads up to 10 psi (1,440 psf) of window area.

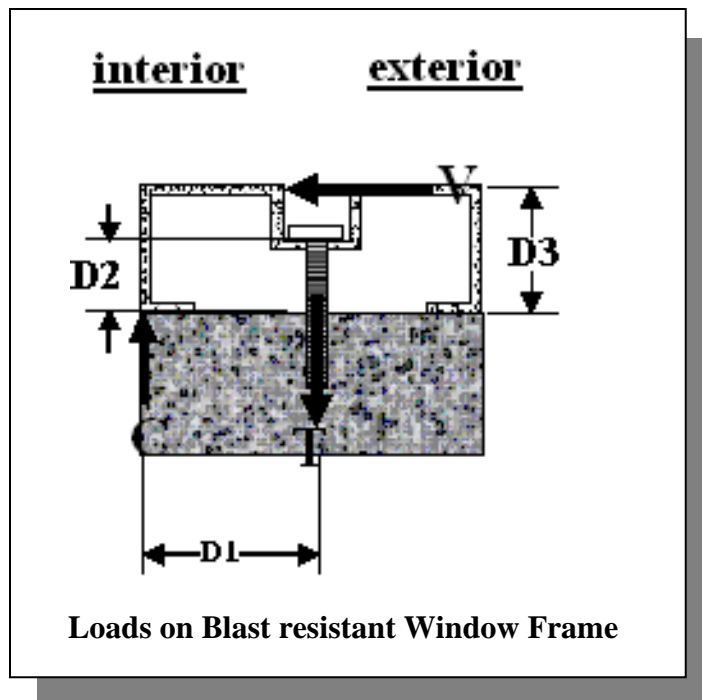

Civil Engineering Structures - ARCHTEC

Cintec anchors have been used for the repair and reinforcement of a number of civil engineering structures.

The ARCHTEC system for reinforcement of masonry arch bridges has been proven by full scale laboratory test to failure.

Cintec Earth anchors have been used to reinforce seawalls and railway embankments.

Cintec anchors are particularly useful in the repair of hydraulic structures such as dam. The sock retains the grout, thus preventing pollution of the watercourse.

Design of repair and upgrading of civil structures is a complex process. The applications are many and varied. It is recommended that the designer of such projects wishing to assess the feasibility of a Cintec application contact Cintec at an early stage in the project. Cintec retains structural engineers experienced in retrofit and upgrading of civil structures to provide assistance to project engineers.

Section 10 – Test Data, Technical References, Standards

Cintec Test Data

Cintec has amassed a substantial collection of physical test data for various types of applications. Test data includes full scale arch bridge tests to failure, pull out tests, shear tests, freeze-thaw durability and fire resistance testing.

Cintec's approach to testing is to use full scale test setups , replicating as close as possible the intended application

Some are controlled laboratory tests. Others are field tests of actual applications.

Tests have been witnessed and certified by Licensed Professional Engineers and/or Certified Testing Agencies.

A considerable amount of test data information is found on Cintec's website in the engineering section.

A collection of hardcopy test data selected for relevance to a specific application is available on request to qualified engineers.

Cintec's Website:

www.cintec.com



ENGINEERING MANUAL, 2020

WWW.CINTEC.COM

Anchoring + Reinforcement
Engineering

Standards

Cintec is a proprietary system using standard materials.

The anchor body is typically Stainless-Steel material. This covered by ANSI standard 304 or 2206. & ASTM A276, A567 & A955

The Presstec grout is a cementitious material covered by the relevant grout / mortar standards relevant to the intended type of application.

The woven fabric sock, while an integral part of the anchor, does not contribute to the structural strength of the anchor and thus is not covered by construction standards.

An ICC legacy report (copy attached) has been obtained for a specific type of anchor used in seismic reinforcement in California, and is applicable to other areas of North America.



Unit Display:



[Printer Friendly Datasheet](#)

Carpenter Stainless Type 304/304L

[Email Datasheet](#)
[Add to My Materials](#)

Identification

UNS Number

- S30400/S30403

Type Analysis

Single figures are nominal except where noted.

Carbon (Maximum)	0.03	% Manganese (Maximum)	2.00	%
Phosphorus (Maximum)	0.045	% Sulfur (Maximum)	0.030	%
Silicon (Maximum)	1.00	% Chromium	18.00 to 20.00	%
Nickel	8.00 to 12.00	% Iron	Balance	

General Information

Description

Carpenter Stainless Type 304/304L is a low-carbon version of Type 304.

In this low-carbon austenitic alloy, control of carbon to a maximum of 0.03% has been shown to minimize carbide precipitation during welding. Customers have reported the use of this steel in corrosive service in the as-welded condition.

Carpenter Stainless Type 304/304L is suggested for applications requiring a moderate level of improvement in machinability for shorter runs of less complex parts, particularly at larger bar diameters.

Manufacturers interested in realizing the potential economic benefits and lower costs associated with higher machining speeds and lower cycle times should consider Project 70+® Type 304/304L stainless.

Customers have reported that Project 70+® Type 304/304L stainless offers significantly improved machinability characteristics over generic Carpenter Stainless Type 304/304L. This includes up to 50% and higher machining speeds with improved finishes and longer tool life.

Applications

Carpenter Stainless Type 304/304L should be considered for use in a wide range of food processing, dairy and dyeing industry applications, such as pipelines, buckets, sterilizers and other types of preparation and processing equipment.

Scaling

The safe scaling temperature for continuous service is 1600°F (871°C).

Corrosion Resistance

Annealed Carpenter Stainless Type 304/304L has proven to be resistant to atmospheric corrosion, foodstuffs, sterilizing solutions, many organic chemicals and dyestuffs, and a wide variety of inorganic chemicals.

For optimum corrosion resistance, surfaces must be free of scale, lubricants, foreign particles, and coatings applied for drawing and heading. After fabrication of parts, cleaning and/or passivation should be considered.

Important Note: The following 4-level rating scale is intended for comparative purposes only. Corrosion testing is recommended; factors which affect corrosion resistance include temperature, concentration, pH, impurities, aeration, velocity, crevices, deposits, metallurgical condition, stress, surface finish and dissimilar metal contact.

Nitric Acid	Good	Sulfuric Acid	Moderate
Phosphoric Acid	Moderate	Acetic Acid	Moderate
Sodium Hydroxide	Moderate	Salt Spray (NaCl)	Good
Sea Water	Restricted	Sour Oil/Gas	Moderate
Humidity	Excellent		

Properties

Physical Properties

Specific Gravity

-- 7.90

Density

-- 0.2850 lb/in³

Mean Specific Heat

32 to 212°F 0.1200 Btu/lb/°F

Mean CTE

32 to 1200°F 10.4 x 10⁻⁶ in/in/°F

Electrical Resistivity

73°F 433.0 ohm-cir-mil/ft

Typical Mechanical Properties

- [Typical Room Temperature Mechanical Properties](#)

Heat Treatment

Annealing

Heat to 1850/2050°F (1010/1121°C) and quench in water. Brinell hardness approximately 150.

Hardening

Cannot be hardened by heat treatment. Can be hardened only by cold working.

Workability

Hot Working

Carpenter Stainless Type 304/304L can be readily forged, hot headed, riveted and upset. Because of its high hot hardness, more power for a given reduction is required than with mild steel.

Forging

To forge, heat uniformly to 2100/2300°F (1149/1260°C). Do not forge below 1700°F (927°C). Forgings can be air cooled without danger of cracking.

For full corrosion resistance, forgings must be annealed.

Cold Working

Carpenter Stainless Type 304/304L is readily fabricated by cold working. Being extremely tough and ductile, it responds to deep drawing, bending, forming and upsetting. After cold working, it is slightly magnetic.

The tensile strength and hardness of Carpenter Stainless Type 304/304L can be materially increased by cold working.

Machinability

Carpenter Stainless Type 304/304L machines with chip characteristics that are tough and stringy. The use of chip curlers or chip breakers is advised. Since the austenitic stainless steels work harden rapidly, heavy positive feeds should be used.

Following are typical feeds and speeds for Carpenter Stainless Type 304/304L.

- [Machinability Tables](#)

Additional Machinability Notes

When using carbide tools, surface speed feet/minute (SFPM) can be increased between 2 and 3 times over the high-speed suggestions. Feeds can be increased between 50 and 100%.

Figures used for all metal removal operations covered are average. On certain work, the nature of the part may require adjustment of speeds and feeds. Each job has to be developed for best production results with optimum tool life. Speeds or feeds should be increased or decreased in small steps.

Weldability

Carpenter Stainless Type 304/304L can be satisfactorily welded by the shielded fusion and resistance welding processes. Since austenitic welds do not harden on air cooling, the welds should have good toughness.

Oxyacetylene welding is not recommended since carbon pickup in the weld may occur.

The alloy can be welded without danger of loss of corrosion resistance due to intergranular carbide precipitation. Usually the alloy can be used in the as-welded condition; however, for service in the most severe environments, the welded structure should be reannealed.

Where a filler metal is required, AWS E/ER 308 or E/ER 347 welding consumables should be considered.

Other Information

Applicable Specifications

- AMS 5639
- AMS 5697
- ASTM A193
- ASTM A314
- ASTM A479
- QQ-S-763
- AMS 5647
- ASTM A182
- ASTM A276
- ASTM A320
- MIL-S-862
- QQS-W-423

Forms Manufactured

- Bar-Hexagons
- Bar-Rounds

Technical Articles

- [A Designer's Manual On Specialty Alloys For Critical Automotive Components](#)
- [Alloy Selection for Cold Forming \(Part I\)](#)
- [Alloy Selection for Cold Forming \(Part II\)](#)
- [New Ideas for Machining Austenitic Stainless Steels](#)
- [New Stainless for Fasteners Combines Corrosion Resistance, High Hardness and Cold Formability](#)
- [Selecting Optimal Stainless Steels for Bio-Pharmaceutical Service](#)
- [Selecting Stainless Steels for Valves](#)
- [Selection of High Strength Stainless Steels for Aerospace, Military and Other Critical Applications](#)
- [Specialty Alloys And Titanium Shapes To Consider For Latest Medical Materials Requirements](#)
- [Stainless Steel Rebar For Concrete Reinforcement: An Update And Selection Guide](#)
- [Steels for Strength and Machinability](#)

Disclaimer:

The information and data presented herein are typical or average values and are not a guarantee of maximum or minimum values. Applications specifically suggested for material described herein are made solely for the purpose of illustration to enable the reader to make his/her own evaluation and are not intended as warranties, either express or implied, of fitness for these or other purposes. There is no representation that the recipient of this literature will receive updated editions as they become available.

Unless otherwise specified, registered trademarks are property of CRS Holdings Inc., a subsidiary of [Carpenter Technology Corporation](#).
Copyright 2016 CRS Holdings Inc. All rights reserved.

Edition Date: 07/01/2000



Unit Display:

[Printer Friendly Datasheet](#)

EnduraMet® 2205 Stainless

[Email Datasheet](#)
[Add to My Materials](#)

Identification

UNS Number

- S31803

DIN Number

- 1.4462

Type Analysis

Single figures are nominal except where noted.

Carbon (Maximum)	0.03	%	Manganese (Maximum)	2.00	%
Phosphorus (Maximum)	0.030	%	Sulfur (Maximum)	0.020	%
Silicon (Maximum)	1.00	%	Chromium	22.00	%
Nickel	5.50	%	Molybdenum	3.00	%
Nitrogen (Maximum)	0.20	%	Iron	Balance	

General Information

Description

EnduraMet® 2205 stainless is a duplex stainless steel that has a microstructure consisting of austenite and ferrite phases. This duplex microstructure and the chemical composition of EnduraMet 2205 stainless results in an excellent combination of strength and corrosion resistance.

EnduraMet 2205 stainless has twice the annealed yield strength of typical austenitic stainless steels, like Type 304 and 316. In the hot rolled unannealed condition, yield strength of 75 ksi (518 MPa) or higher can be achieved for bar diameters up to 1.375 in. (34.925mm).

EnduraMet 2205 stainless possesses good resistance to general corrosion in many acid environments and, has excellent resistance to chloride stress corrosion cracking, pitting and crevice corrosion.

Applications

Rebar has been a primary application for EnduraMet 2205 stainless. Specific rebar applications have included bridge decks, barrier and retaining walls, anchoring systems, chemical plant infrastructure, coastal piers and wharves, bridge parapets, sidewalks and bridge piling. The higher strength capability, 75 ksi (518 MPa) minimum yield strength, of EnduraMet 2205 stainless rebar is an added economical advantage.

Other applications for EnduraMet 2205 stainless have included bridge tie wire and dowels; oil and gas production equipment, such as valves, fittings, shafts, and pump parts; heat exchangers in chemical and

pulp and paper plants; and brewery tanks.

Elevated Temperature Use

EnduraMet 2205 stainless is subject to 885 embrittlement when exposed for extended times between about 700 and 1000°F (371 and 538°C).

The alloy is also subject to precipitation of sigma phase when exposed between about 1250 and 1550°F (677 and 843°C) for extended time. Sigma phase increases strength and hardness, but decreases ductility and corrosion resistance.

Corrosion Resistance

EnduraMet 2205 stainless has good resistance to atmospheric corrosion and long-term resistance to general corrosion when embedded in concrete. In the 15 week corrosion macrocell test in simulated concrete pore solution, EnduraMet 2205 stainless had an average corrosion rate less than 0.25 micrometer/yr.

Compared to conventional austenitic stainless steels, like Type 304 and 316, EnduraMet 2205 stainless has superior resistance in most oxidizing and reducing acids; superior chloride pitting and crevice corrosion resistance, due to higher chromium, molybdenum and nitrogen content and superior resistance to chloride stress corrosion cracking due to its duplex microstructure.

EnduraMet 2205 stainless has good intergranular corrosion in the as-annealed and as-weld conditions due to its low carbon content.

For optimum corrosion resistance, surfaces must be free of scale, lubricants, foreign particles, and coatings applied for drawing and heading. After fabrication of parts, cleaning and/or passivation should be considered.

Important Note: The following 4-level rating scale is intended for comparative purposes only. Corrosion testing is recommended; factors which affect corrosion resistance include temperature, concentration, pH, impurities, aeration, velocity, crevices, deposits, metallurgical condition, stress, surface finish and dissimilar metal contact.

Nitric Acid	Good	Sulfuric Acid	Moderate
Phosphoric Acid	Moderate	Acetic Acid	Good
Sodium Hydroxide	Moderate	Salt Spray (NaCl)	Excellent
Sea Water	Moderate	Sour Oil/Gas	Moderate
Humidity	Excellent		

Properties

Physical Properties

Specific Gravity

Annealed	7.80
As Rolled	7.82

Density

Annealed	0.2820	lb/in ³
As Rolled	0.2830	lb/in ³

Mean CTE

77 to 122°F, Annealed	6.22	x 10 ⁻⁶ in/in/°F
77 to 212°F, Annealed	7.11	x 10 ⁻⁶ in/in/°F
77 to 302°F, Annealed	7.29	x 10 ⁻⁶ in/in/°F
77 to 392°F, Annealed	7.53	x 10 ⁻⁶ in/in/°F
77 to 482°F, Annealed	7.72	x 10 ⁻⁶ in/in/°F
77 to 572°F, Annealed	7.86	x 10 ⁻⁶ in/in/°F
77 to 662°F, Annealed	7.97	x 10 ⁻⁶ in/in/°F
77 to 752°F, Annealed	7.99	x 10 ⁻⁶ in/in/°F
77 to 842°F, Annealed	8.12	x 10 ⁻⁶ in/in/°F
77 to 932°F, Annealed	8.23	x 10 ⁻⁶ in/in/°F
77 to 1012°F, Annealed	8.30	x 10 ⁻⁶ in/in/°F
77 to 1112°F, Annealed	8.44	x 10 ⁻⁶ in/in/°F
77 to 1202°F, Annealed	8.57	x 10 ⁻⁶ in/in/°F
77 to 1292°F, Annealed	8.77	x 10 ⁻⁶ in/in/°F
77 to 122°F, Hot Rolled	7.02	x 10 ⁻⁶ in/in/°F
77 to 212°F, Hot Rolled	7.48	x 10 ⁻⁶ in/in/°F
77 to 302°F, Hot Rolled	7.70	x 10 ⁻⁶ in/in/°F
77 to 392°F, Hot Rolled	7.82	x 10 ⁻⁶ in/in/°F
77 to 482°F, Hot Rolled	8.04	x 10 ⁻⁶ in/in/°F
77 to 572°F, Hot Rolled	8.17	x 10 ⁻⁶ in/in/°F
77 to 662°F, Hot Rolled	8.26	x 10 ⁻⁶ in/in/°F
77 to 752°F, Hot Rolled	8.34	x 10 ⁻⁶ in/in/°F
77 to 842°F, Hot Rolled	8.44	x 10 ⁻⁶ in/in/°F
77 to 932°F, Hot Rolled	8.53	x 10 ⁻⁶ in/in/°F
77 to 1012°F, Hot Rolled	8.57	x 10 ⁻⁶ in/in/°F
77 to 1112°F, Hot Rolled	8.68	x 10 ⁻⁶ in/in/°F
77 to 1202°F, Hot Rolled	8.78	x 10 ⁻⁶ in/in/°F
77 to 1292°F, Hot Rolled	8.92	x 10 ⁻⁶ in/in/°F

- [Mean Coefficient of Thermal Expansion](#)

Magnetic Properties

In the annealed and hot rolled conditions, EnduraMet 2205 stainless is ferromagnetic.

Typical Mechanical Properties

- [CVN Impact Data](#)
- [Mechanical Properties - Various Test Temperatures](#)
- [RR Moore Rotating Beam Fatigue Tests](#)
- [Typical Room Temperature Hot Rolled Mechanical Properties](#)

Heat Treatment

Annealing

Heat to 1850/2050°F (1010/1121°C) and rapidly quench in water or air. Typical hardness as-annealed is

HRC 20.

Hardening

Cannot be hardened by heat treatment. Can be hardened only by cold working.

Workability

Hot rolling and controlling the finishing temperature can strengthen EnduraMet 2205 stainless bar. After hot rolling, bars are not annealed.

Hot Working

Heat uniformly to 2000/2100°F (1093/1149°C). Reheat as often as necessary. Cool forgings in air.

Cold Working

Cold working increases strength and hardness. Work hardening rate is lower than Type 304; however, the annealed strength is significantly higher.

Machinability

The machinability of EnduraMet 2205 stainless generally has been between that of conventional Type 316 stainless and Carpenter 22Cr-13Ni-5Mn stainless.

The following chart includes typical machining parameters used to machine EnduraMet 2205 stainless. The data listed should be used as a guide for initial machine setup only.

- [Machinability Tables](#)

Weldability

EnduraMet 2205 stainless has been welded using many of the standard electric arc welding processes. Autogeneous welding will increase the amount of ferrite present in the weldment and heat affected zone. When a filler metal is required, consider AWS E/ER 2209.

Oxyacetylene welding is not recommended, because carbon pickup in the weld may occur.

Post weld annealing is not required for most applications, but will provide optimum properties for severe service.

Other Information

Applicable Specifications

- ASME SA479
- ASTM A276
- ASTM A955M
- NACE MR0175
- ASTM A240
- ASTM A479
- BS 6744: 2001

Forms Manufactured

- Bar-Rounds
- Rebar or (Bar-Reinforcing)
- Wire
- Billet
- Strip
- Wire-Rod

Technical Articles

- [Extending the Life of Concrete Structures with Solid Stainless Steel Reinforcing Bar](#)
- [Stainless Steel Rebar For Concrete Reinforcement: An Update And Selection Guide](#)

Disclaimer:

The information and data presented herein are typical or average values and are not a guarantee of maximum or minimum values. Applications specifically suggested for material described herein are made solely for the purpose of illustration to enable the reader to make his/her own evaluation and are not intended as warranties, either express or implied, of fitness for these or other purposes. There is no representation that the recipient of this literature will receive updated editions as they become available.

Unless otherwise specified, registered trademarks are property of
CRS Holdings Inc., a subsidiary of [Carpenter Technology Corporation](#).

Copyright 2016 CRS Holdings Inc. All rights reserved.

Edition Date: 1/30/12

ICC Evaluation Service Report

ICC EVALUATION SERVICE, INC.

Evaluate P Inform P Protect

Los Angeles Business/Regional Office P 5360 Workman Mill Road P Whittier, CA 90601 (562) 699-0543 phone P (562) 695-4694 fax

ICC EVALUATION SERVICE, INC.

Evaluate ■ Inform ■ Protect

Los Angeles Business/Regional Office ■ 5360 Workman Mill Road ■ Whittier, CA 90601
(562) 699-0543 phone ■ (562) 695-4694 fax



August 25, 2004

Robert Lloyd-Rees Chief Operating Officer Cintec Canada Ltd. 38 Auriga Drive,
Suite 200 Nepean, Ontario K2E 8A5 Canada

RE: ER-6087 March 1, 2004

Dear Mr. Lloyd-Rees:

This letter constitutes final approval of the ICC Evaluation Service, Inc. (ICC-ES), legacy report referenced above, and authorizes use of the report in accordance with the ICC-ES Rules of Procedure for Legacy Reports. Any further changes to the report cannot be accepted unless they involve an application for an interim revision or reexamination. The report will be due for re-examination on March 1, 2005, and may not be used or referenced beyond the re-examination date except with the permission of ICC-ES. Your report will be available on our web site at www.icc-es.org.

Enclosed with this letter are electronic copies of the evaluation report and the Rules of Procedure for Legacy Reports. Use of the evaluation report and the report number must be in accordance with Section 15.0 of the Rules. The ICC-ES name or report number shall not be used in a manner which could be misleading, nor shall the name or report number appear on documents that display or indicate products or systems that are not recognized in the evaluation report. All test results noted in your literature where the ICC-ES name or report number appear shall be consistent with the evaluation report. Failure to comply with the ICC-ES Rules of Procedure can result in cancellation of your evaluation report.

If you would like some suggested text for your product literature, we offer the following:

“[Name of company] has received confirmation from ICC Evaluation Service, Inc. (ICCES), that its [name of product] complies with the provisions of the [list applicable codes].

This confirmation, as evidenced in ICC-ES evaluation report ER-xxxx, provides guidance to code officials faced with approving the use of [name of product] under these codes. The =evaluation report is available online at www.icc-es.org.”

We appreciate this opportunity to serve you and ask that you feel free to contact us when we can be of assistance.

A handwritten signature in black ink that reads "Gary G. Nichols". The signature is written in a cursive, flowing style.

GN:ls Enclosures (evaluation report, rules for legacy reports)



LEGACY REPORT

ER-6087

Issued March 1, 2004

ICC Evaluation Service, Inc.
www.icc-es.org

Business/Regional Office ■ 5360 Workman Mill Road, Whittier, California 90601 ■ (562) 699-0543
Regional Office ■ 900 Montclair Road, Suite A, Birmingham, Alabama 35213 ■ (205) 599-9800
Regional Office ■ 4051 West Flossmoor Road, Country Club Hills, Illinois 60478 ■ (708) 799-2305

Legacy report on the 1997 *Uniform Building Code*™, the 1997 *Uniform Code for Building Conservation*, and the 2000 *International Building Code*®

DIVISION: 04—MASONRY
Section: 04080—Masonry Anchorage and Reinforcement

CINTEC PIPE ANCHOR RETROFIT SYSTEM

CINTEC CANADA LTD.
38 AURIGA DRIVE, SUITE 200
NEPEAN, ONTARIO K2E 8A5
CANADA

CINTEC AMERICA, INC.
5506 CONNECTICUT AVENUE N.W. #28
WASHINGTON, DC 20015

1.0 SUBJECT

Cintec Pipe Anchor Retrofit System for Unreinforced Masonry (URM) and Nonductile Concrete Buildings.

2.0 DESCRIPTION

2.1 General:

2.1.1 The Cintec Pipe Anchor Retrofit System is used to retrofit unreinforced masonry (URM) structures and nonductile concrete structures. Figure 1 provides details of the system.

2.1.2 Codes and Standards: The following codes and code-related documents are incorporated by reference into this report: 1997 *Uniform Code for Building Conservation* (UCBC); 1997 *Uniform Building Code*™ (UBC); 2001 ICBO *Guidelines for Rehabilitation of Existing Buildings*, 1st edition; 2001 ICBO *Guidelines for Seismic Retrofit of Existing Buildings*; 2000 *International Building Code*® (IBC); *Building Code Requirements for Structural Concrete* (ACI 318-99), *Structural Steel Buildings—Allowable Stress Design and Plastic Design* (AISC ASD, 1989); and *Load and Resistance Factor Design for Structural Steel Buildings*, including Supplement No. 1 dated January 1998 (AISC LRFD, 1993).

2.2 Materials:

2.2.1 Pipe Anchors: The Cintec Pipe Anchors are standard pipe or round, hollow structural sections complying with ASTM A 618 Grade 50, with dimensions and design properties described in the *Manual of Steel Construction, Load and Resistance Factor Design or Allowable Stress Design*, published by the American Institute of Steel Construction.

2.2.2 Concrete Fill: The interior area of the pipe shall be filled with normal-weight or structural lightweight concrete having, respectively, a minimum 3,000 psi (20.7 MPa) or a minimum 4,000 psi (27.6 MPa) compressive strength at 28 days. Concrete quality, mixing, and placing shall comply with Chapter 19 of the UBC or with ACI 318-99 (IBC).

2.2.3 Concrete Footings: Normal-weight concrete having a minimum 3,000 psi compressive strength at 28 days shall be used for footings. Concrete quality, mixing, and placing shall comply with Chapter 19 of the UBC or with ACI 318-99 (IBC).

2.2.4 Concrete Reinforcement: Deformed steel reinforcement bars shall comply with ASTM A 615, A 616, A 617, or A 706 Grade 60. Steel joint reinforcement for masonry shall comply with ASTM A 951 or UBC Standard 21-10 (Part I).

2.3 Design:

2.3.1 Design Loads:

The design loads for the structure shall be calculated in accordance with the UCBC, UBC, IBC, *Guidelines for Rehabilitation of Existing Buildings*, or *Guidelines for Seismic Retrofit of Existing Buildings*, as applicable.

2.3.2 Analysis of the Existing Structure Materials: The existing structure shall be evaluated for in-situ material strengths in accordance with the procedures in Section 1920 of the UBC, the UCBC, Section 1916 of the IBC, or the *Guidelines for Seismic Retrofit of Existing Buildings*, as applicable.

2.3.3 Structural Analysis Methods: The existing structural system with the Cintec Pipe Anchor System shall be evaluated using a combination of structural methodologies described in the UBC, IBC, ACI 318-99 (IBC), AISC ASD (1989) and AISC LRFD (1993). These include linear methods, nonlinear methods, and elastic design of structural elements in accordance with the referenced codes and standards. The designer may utilize either the AISC ASD (1989) or the AISC LRFD (1993) for the design of the Cintec Pipe Anchor System.

2.3.4 Composite Columns: The design requirements for composite columns are contained in Section I2 of AISC ASD (1989) or AISC LRFD (1993). In accordance with AISC LRFD (1993), the 4 percent area limitation defines the composite action behavior for steel tube columns. According to the

ICC-ES legacy reports are not to be construed as representing aesthetics or any other attributes not specifically addressed, nor are they to be construed as an endorsement of the subject of the report or a recommendation for its use. There is no warranty by ICC Evaluation Service, Inc., express or implied, as to any finding or other matter in this report, or as to any product covered by the report.



LRFD Section I2, 4 percent of the gross area of the section allows for the column to be designed in accordance with LRFD specifications.

2.3.5 Deformation Limits and Drift Requirements: The maximum out-of-plane deformation shall be $0.005h$, where h is the wall height between supports. The maximum in-plane story drift shall be $0.007h$.

2.3.6 Connection Methods: The Cintec Pipe Anchor System is to be detailed in accordance with the applicable code. Holes shall be provided in horizontal pipe anchors to accommodate interaction with vertical pipe anchors. Holes shall be provided in vertical pipe anchors to accommodate wall ties.

2.3.7 Foundation Connections: The foundation connection between the Cintec Pipe Anchor and the substructure shall be the responsibility of the registered design professional and shall be detailed in accordance with the appropriate site/field conditions. The structural design shall comply with the applicable code, and structural engineering practice. Foundation connections shall be designed and installed for each specific project.

2.3.8 Design Plans and Specifications: The design plans and specifications shall be prepared by a registered design professional. Cintec shall maintain a list of registered design professionals qualified to perform the design in accordance with this report and its requirements, and only those authorized registered design professionals are allowed to utilize this system.

2.4 Installation:

Holes accommodating the anchors and wall ties shall be drilled into the concrete or masonry wall using nonpercussive drilling procedure. Wall tie holes measuring $\frac{3}{4}$ inch (19 mm) in diameter are drilled in the specified locations, and steel guides are inserted to assist in positioning anchor holes. Anchor holes measuring larger than the outside pipe anchor dimension are drilled through the wall, directed by the steel guides. Maximum vertical anchor spacings are 24 inches (610 mm). After drilling, the base of the hole is enlarged using a taper drill. Pipe anchors are placed in the holes after all debris is removed. The steel guides are then removed and wall ties are placed through the holes into the anchors. The wall ties are set in grout, which must cure before anchor interiors are

injected with concrete. The drilling shall be performed only by Cintec qualified/certified drilling installers under the quality control supervision of Cintec personnel.

2.5 Quality Control and Special Inspection:

Each project shall incorporate a quality control program in accordance with Chapter 17 of the UBC or IBC. The preparation of anchors (holes and length) shall be done by fabricators approved by the building official in accordance with Section 1701.7 of the UBC or Section 1704.2.2 of the IBC. Special inspection is required in accordance with Section 1701 of the UBC or Section 1704 of the IBC. The inspector's duties include verifying that anchors were prepared by an approved fabricator; that anchors, wall ties, and concrete comply with specifications; that there are proper drilling operations, proper anchor and wall tie placement, and proper concrete placement; and that concrete test specimens are properly prepared. Under the IBC, quality assurance plans shall be submitted to the building official for approval as required by Sections 1705 and 1706.

3.0 EVIDENCE SUBMITTED

Structural calculations and installation instructions.

4.0 FINDINGS

That the Cintec Pipe Anchor Retrofit System for unreinforced masonry (URM) and nonductile concrete buildings described in this report complies with the 1997 Uniform Building Code™, the 1997 Uniform Code for Building Conservation, and the 2000 International Building Code® (IBC), subject to the following conditions:

- 4.1 Design and installation are in accordance with this report, the manufacturer's instructions and the applicable code.**
- 4.2 Fire-resistance of the assembly must comply with Chapter 7 of the UBC or IBC. Fire protection for the assemblies shall be subject to building official approval.**
- 4.3 Quality control is provided in accordance with Section 2.5 of this report.**

This report is subject to re-examination in one year.

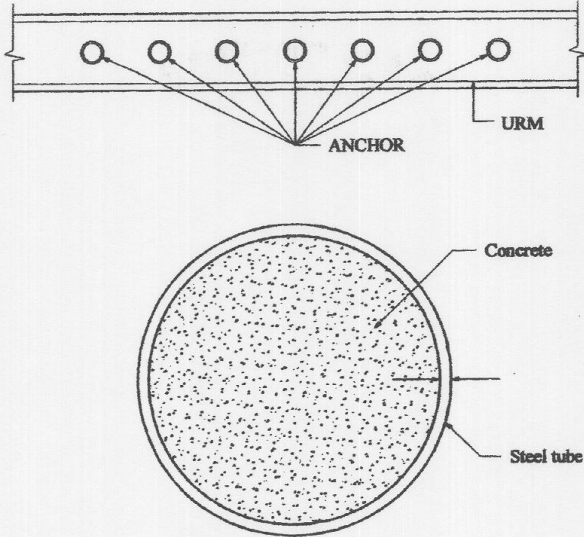

FIGURE 1—CINTEC ANCHOR

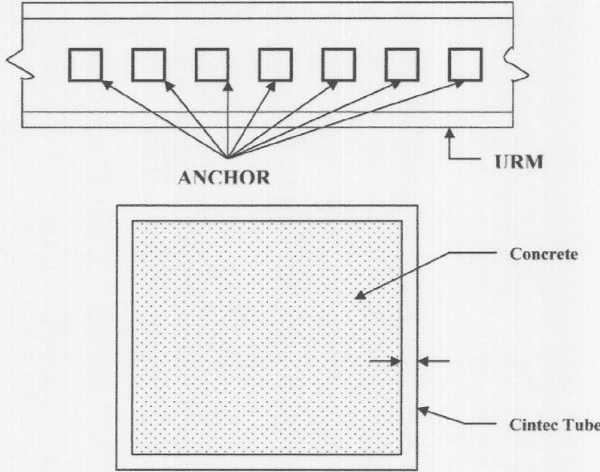
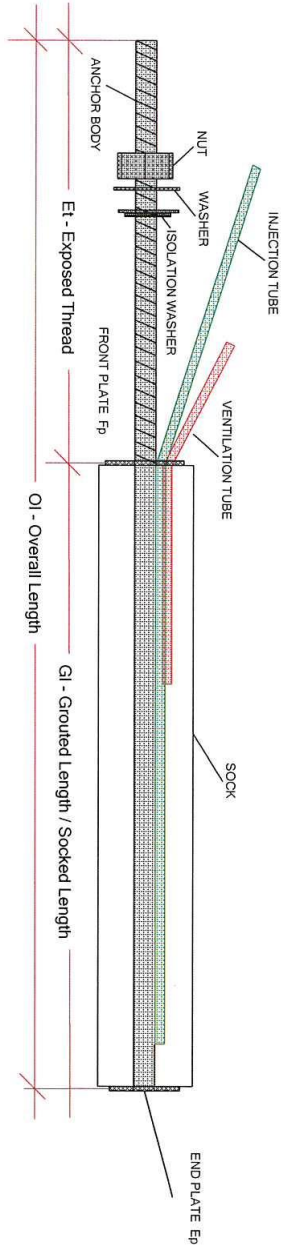
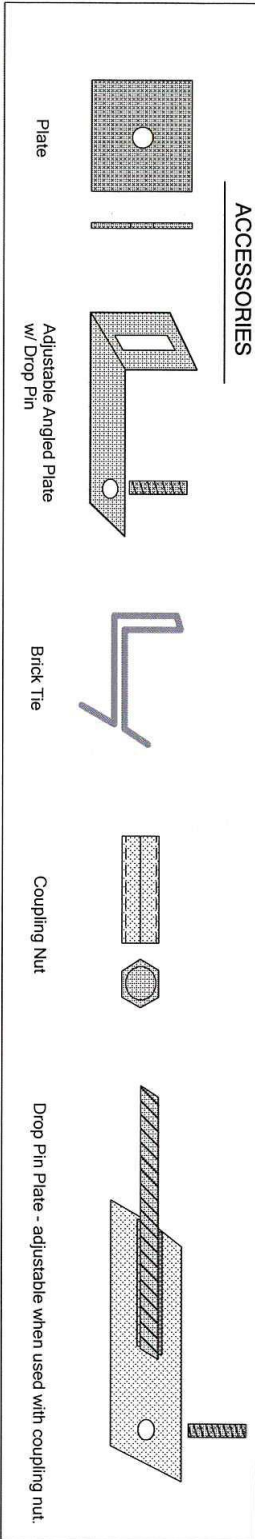

FIGURE 2—SQUARE TUBE REINFORCEMENT

GENERIC SRT ANCHOR WITH EXPOSED THREAD



ACCESSORIES



CINTEC TERMINOLOGY

- Accessory - end treatment that can be attached to an anchor
- Anchor Body - the steel part of the anchor. Usually stainless steel and may be hollow, solid round, square, or other configuration.
- Nut - hexagonal with same ID as body and usually of same material.
- Plate (End) - on most anchors. Usually 1/2" smaller diameter than the core/ sock diameter. Has hole in centre the size of body so it can be welded / threaded in place.
- Plate (Front) - on some anchors. Usually 1/2" smaller diameter than the core/ sock diameter. Has hole in centre the size of body so it can be welded / threaded in place. May also have "port (s)" to accommodate injection / ventilation / other tubes.

- Sock - polyester, woven tube usually size matched to the core hole diameter... but NOT always
- Tube (Injection) - tube that is glued in place and used to INJECT the anchor sock. It is the longest tube if two or more tubes are present and identified with a sticker with green writing.
- Tube (ventilation) - also called "emergency" allows air insystem to escape and can also be used if absolutely necessary to inflate anchor. It is glued in place and is the shortest tube. If two or more tubes are present and identified with a sticker with red writing.
- Washer - also called flat or fender washer.
- Washer (Isolation) - also called bonded washer, used to prevent galvanic action between dissimilar materials

FRONT PLATES (Various)

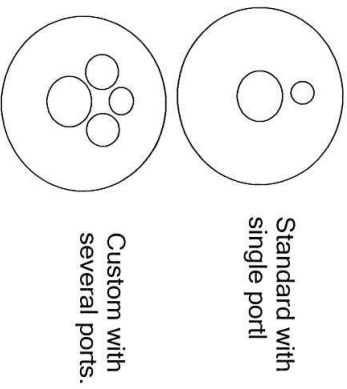

CPD 2018

Section 11 – Information

Cintec has an extensive database of structural reinforcement, masonry restoration and terra cotta repairs and details.

For more information please visit www.cintec.com or email engineering@cintec.com.