

CINTEC

Preservation Technology

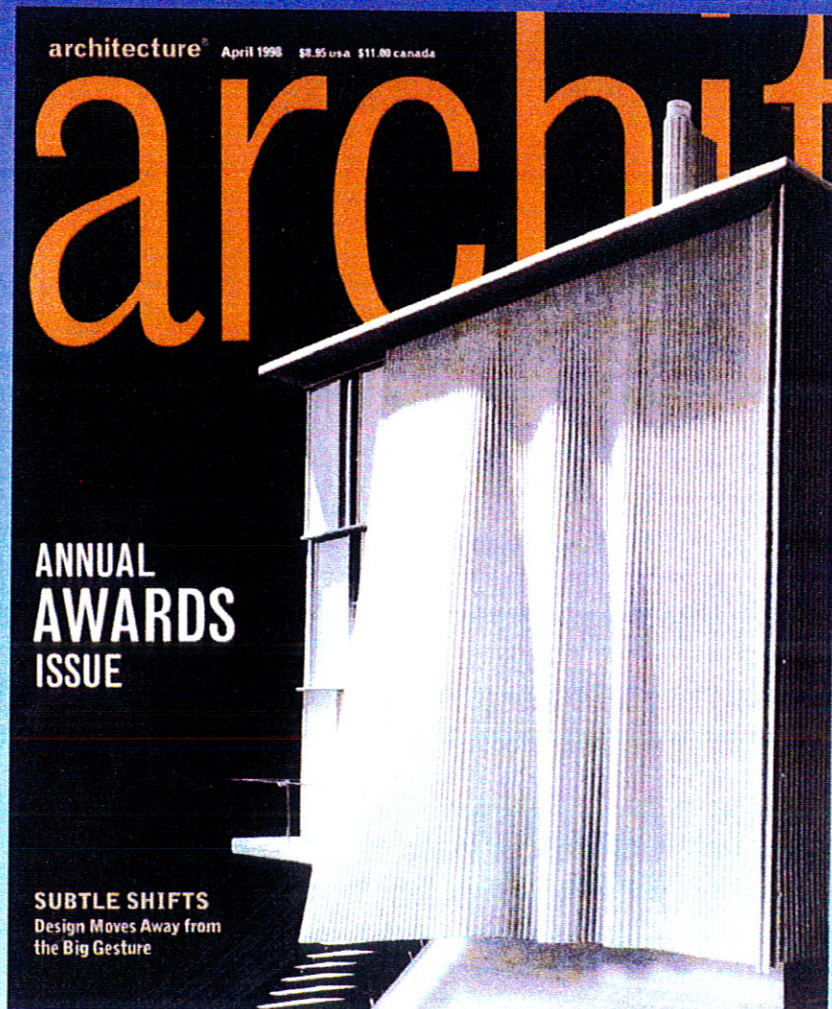

As featured in the
American Publication
'Architecture'

Reproduced with Permission of Publishers

Preservation Technology **Cutting-Edge Masonry Repair**

Steering away from epoxies, new technologies help patch, clean, straighten, and strengthen historic brick and stone buildings

By Eric Adams

If masonry is one of architecture's true constants, masonry repair is one of historic preservation's. Brick and stone are among the most versatile and durable building materials, but they're prone to wear and damage from wind, rain, and all manner of human assault.

Fortunately, historic preservation specialists and product manufacturers are working to stay ahead of masonry decay. Several innovative new technologies help in virtually every area of masonry repair, including strengthening, repointing, cleaning, connectivity, and void and crack repair. These methods range from advanced anchoring systems and sophisticated cleaning devices to carefully prepared and applied mortars and grouts.

Although new repair techniques sometimes introduce modern materials into historic fabric, they are all designed to aid historically faithful preservation efforts while supporting necessary cosmetic and structural repairs. The techniques respond to the concerns of architects, conservators, and contractors about an historic building's ability to breathe and move naturally. They also resolve more general issues of material and historical fidelity. In particular, experts are shying away from chemical-based

fixes, such as epoxies or resins, and from high-strength mortars, both of which can damage buildings more than the forces they are trying to correct.

"Compatibility is the key when fixing old masonry," explains Michael Schuller of Atkinson-Noland Associates, a masonry evaluation and repair consultant in Boulder, Colorado. "If you place a really stiff material, such as mortar, next to a softer material, you'll likely get cracking and spalling in the masonry. If there's an epoxy barrier, you'll have water-vapour transmission problems."

Strengthening masonry walls

Perhaps the most dramatic recent advancements in masonry preservation technology focus on strengthening and connectivity. In the face of seismic forces, wind loads, vibration from vehicles and machinery, inadequate original design, new adaptations, and aging, stabilising masonry is becoming a more critical element of rehabilitation and historic preservation efforts.

Cintec Designed Anchor Systems offers an innovative alternative to invasive or unsightly structural strengthening systems.



Limestone cladding of Essex County New Courts Building and Jail was one accident away from catastrophic failure. More than 20,000 Cintec anchors now prevent masonry's collapse.

The Cintec Anchor system is embedded within masonry walls and can be installed with relative ease and speed. In most cases, there is no need to evacuate a structure during installation.

Developed in the United Kingdom and instrumental in the recent post-fire restoration of Windsor Castle, Cintec anchors, manufactured by CLS Cintec, are deceptively simple. A steel rod wrapped in a fabric sock is inserted into a predrilled hole in the masonry. Once in place, ultrafine concrete grout is pumped into the sock. As the anchor fills, grout milk is forced through the

To install Cintec anchor (right), technicians drill hole, insert nylon sock-covered anchor, and inject grout into sock until anchor is securely wedged into masonry.



sock, creating a chemical bond between the anchor and the substrate. The exterior hole is then patched. The wall is then better able to withstand vertical forces and is generally stronger.

"One of the best things about this system is that the material is cementitious, not epoxy-based," explains Westfield, New Jersey, architect Michael Zemsky. "The most interesting part is that the nylon sock expands to fill the cavity until it is completely wedged in." Zemsky recently specified Cintec anchors on the Essex County New Courts Building and Jail in Newark. The 1966 building's limestone curtain wall panels had separated from the structure, causing damage so pervasive and severe that the building was, in Zemsky's words, "one accident away from catastrophic failure."

Zemsky's general contractor for the courthouse project, Jim Papandrea, says that before they inserted more than 20,000 Cintec anchors into the building, they had an independent lab test the system by measuring the strength of the anchors' hold on the masonry. "The pullout tests exceeded 4,000 pounds," Papandrea says of the procedure, in which steadily increasing force is applied until the anchor fails. "The block broke before the anchor did."

Cintec anchors are available in lengths ranging from 6 inches to hundreds of feet, and can be applied either front to back or lengthwise through a masonry wall. Variations of the system can also stitch together heavily cracked masonry and connect outer external wythes to internal

wythes. The anchors also provide cost savings: Their use in the Newark courthouse project saved the client \$2.5 million over a previous estimate for reanchoring the building's dangerously unstable stonework.

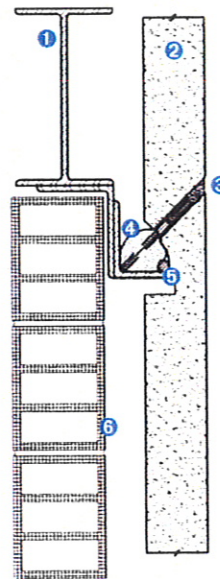

Wall section detail

- 1 structural steel beam
- 2 limestone panels
- 3 Cintec anchor
- 4 expandable nylon sock
- 5 steel relieving angle
- 6 masonry backup
- 7 patching compound
- 8 grout flood hole
- 9 stainless steel member
- 10 end plate

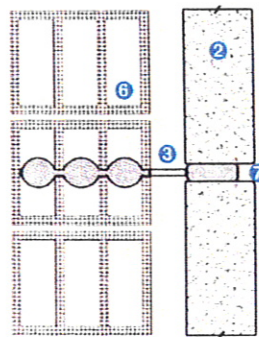

Wall plan detail

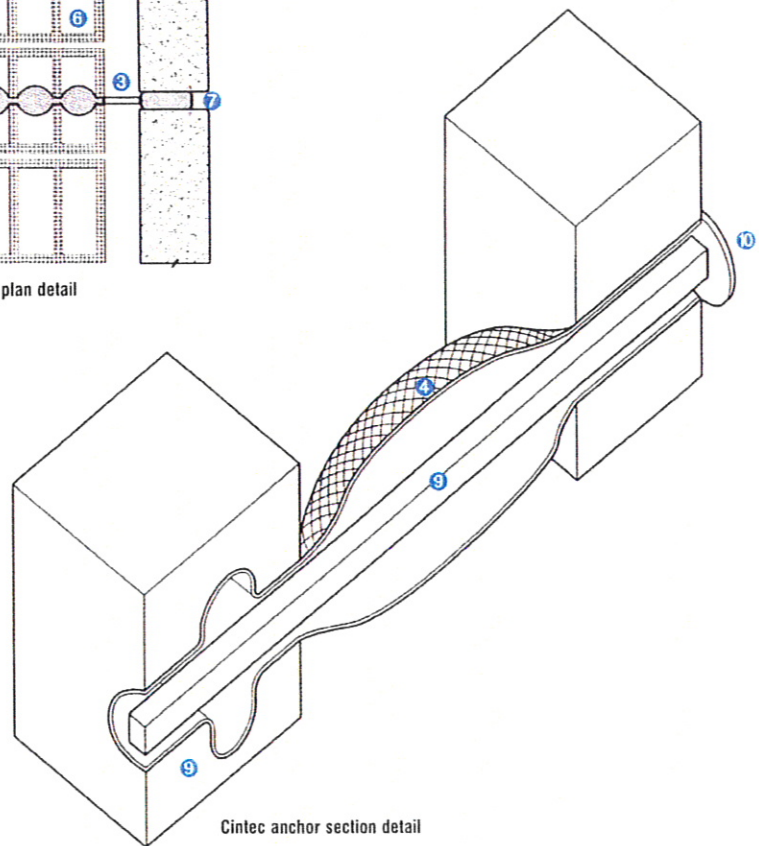

Cintec anchor section detail

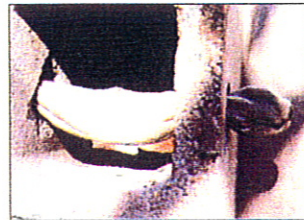

CINTEC

Structural Reinforcement Anchors

Injection Hole
usually double
anchor body size

Main anchor body
available as square
or circular hollow
section or solid
bar profile

Fabric
containing
anchor

Grout injection
moulds anchor to
the shape and spaces
within the wall

Inner wall
substrate



- Designed to the requirements of each application
- Quickly installed
- Age tested for durability
- Fire resistant
- Cementitious, therefore sympathetic to the structure
- Controlled grout flow containment
- Invisible when installed
- Effective for structural repairs, ground anchoring, parapet walls & masonry arch strengthening

United States

Cintec America Inc.
200 International Circle, Suite 5100,
Hunt Valley, Maryland
21030, USA
Tel: 1 410 761-0765
1 800 363-6066
Fax: 1 800 461-1862
E-mail: solutions@cintec.com

Canada

Cintec Reinforcement Systems
38 Auriga Drive, Suite 200
Nepean, Ontario, Canada
K2E 8A5
Tel: (1) 613 225-3381
Fax: (1) 613 224-9042
E-mail: solutions@cintec.com

CINTEC
NORTH AMERICA

SECURING THE PAST FOR THE FUTURE

United Kingdom

Cintec International Ltd.
Cintec House
11 Gold Tops
South Wales, UK
Newport NP204PH
Tel: +44 (0) 1633 246614
Fax: +44 (0) 1633 246110
E-mail: hqcintec@cintec.co.uk

Visit our website for up-to-date
information and test data
together with information on
the various projects carried out
worldwide.

www.cintec.com

